

TM 5-4610-210-14

DEPARTMENT OF THE ARMY TECHNICAL MANUAL

TECHNICAL MANUAL

**OPERATOR, ORGANIZATIONAL, DIRECT AND
GENERAL SUPPORT MAINTENANCE MANUAL,
INCLUDING REPAIR PARTS
AND SPECIAL TOOLS LIST**

**HYPOCHLORINATION UNIT, WATER PURIFICATION,
FRAME MOUNTED, WATER DRIVEN, 100 GPM
(WALLACE AND TIERNAN MODEL A-506111)**

FSN 4610-880-0154

HEADQUARTERS, DEPARTMENT OF THE ARMY

JUNE 1971

CHANGE }
No. 2 }

HEADQUARTERS
DEPARTMENT OF THE ARMY
WASHINGTON, DC, 25 November 1974

**Operator's, Organizational, Direct Support
and General Support Maintenance Manual,
Including Repair Parts and Special Tools List**

**HYPCHLORINATION UNIT, WATER PURIFICATION,
FRAME MOUNTED, WATER DRIVEN, 100 GPM
(WALLACE AND TIERNAN MODEL A-506111)
FSN 4610-880-0154**

TM 5-4610-210-14,12 June 1971, is changed as follows:
Inside front *cover page*. Add warning notice as follows:

WARNING

Dry cleaning solvent PD-680, used to clean parts is potentially dangerous to personnel and property. Do not use near open flame or excessive heat. Flash point of solvent is 100°F — 138°F.

Add caution notice as follows:

CAUTION

Water Purification Equipment Set Turn-In
Opened or broken packages of chemicals (i.e., ferric-chloride, calcium hypochlorite) are highly caustic and can have a deleterious effect, during extended periods of

storage, on the interior surface of the van body and items components.

When turning in a Water purification Equipment Set as unserviceable or excess, the following actions will be taken:

- a. Partially consumed or opened chemicals will be utilized and/or destroyed locally.
- b. All unopened chemicals will be individually packaged and will not be stored for shipment inside of the water purification unit van body.

Page 1-1. Paragraph 1-2b is superseded as follows:

- b. You can improve this manual by recommending improvements using DA Form 2028 (Recommended Changes to Publications and Blank Forms) and mailing the form direct to Commander, US Army Troop Support Command, ATTN: AMSTS-MPP, 4300 Goodfellow Blvd., St. Louis, MO 63120. A reply will be furnished direct to you.

By Order of the Secretary of the Army:

FRED C. WEYAND
General, United States Army
Chief of Staff

Official:

VERNE L. BOWERS
Major General, United States Army
The Adjutant General

Distribution:

To be distributed in accordance with DA Form 12-25A (qty rqr block No. 177), operator maintenance requirements for water purification.

* U.S. GOVERNMENT PRINTING OFFICE: 1974-665136/398

Change }
No. 1 }

HEADQUARTERS
DEPARTMENT OF THE ARMY
Washington, D. C., 12 July 1972

**Operator Organizational, Direct Support and General Support
Maintenance Manual, Including Repair Parts and
Special Tools List
HYPOCHLORINATION UNIT, WATER PURIFICATION,
FRAME MOUNTED, WATER DRIVEN, 100 GPM
(WALLACE AND TIERNAN MODEL A-506111)
FSN 4510-880-0154**

Current as of 22 June 1972

TM 54610-210-14, 12 June 1971, is changed as follows:
Change Cover and contents page to read Direct Support
Page C-1. Appendix C is superseded as follows:

**APPENDIX C
BASIC ISSUE ITEMS LIST AND ITEMS
TROOP INSTALLED OR AUTHORIZED**

Section 1. INTRODUCTION

C-1. Scope

This appendix lists items required by the operator for operation of the Hypochlorination Unit.

C-2. General

This list is divided into the following sections

a. Basic Issue Items List—Section II. Not applicable.

b. Items Troop Installed or Authorized List—Section III. A list of items in alphabetical sequence, which at the discretion of the unit commander may accompany the Hypochlorination Unit. These items are NOT subject to turn-in with the Hypochlorination Unit, when evacuated.

C-3. Explanation of Columns

The following provides an explanation of columns in the tabular list of Basic Issue Items List, Section II, and Items Troop Installed or Authorized, Section III.

a. Source, Maintenance, and Recoverability Code(s) (SMR):

(1) Source Code, indicates the source for the listed item. Source codes are:

Code	Explanation
P.	Repair parts, special tools and test equipment supplied from GSA/DSA or Army supply system and authorized for use at indicated maintenance levels.
P2.	Repair parts, special tools and test equipment which are procured and stocked for insurance purposes because the combat or military essentiality of the end item dictates that a minimum quantity be available in the supply system.

(2) Maintenance Code, indicates the lowest level of maintenance authorized to install the listed item. The maintenance level code is:

Code	Explanation
C .	Crew/Operator

(3) Recoverability Code, indicates whether un-serviceable items should be returned for recovery or salvage. Items not coded are non-recoverable. Recoverability codes are:

Code	Explanation
R.	Applied to repair parts (assemblies and components), special tools and test equipment which are considered

Code Explanation

economically repairable at direct and general support maintenance levels.

SRepair parts, special tools, test equipment and assemblies which are economically repairable at DSU and GSU activities and which normally are furnished by supply on an exchange basis.

b. Federal Stock Number. This column indicates the Federal stock number assigned to the item and will be used for requisitioning purposes.

c. Description. This column indicates the Federal item name and any additional description of the item required.

d. Unit of Measure (U/M). A 2 character alphabetic abbreviation indicating the amount or quantity of

the item upon which the allowances are based, e.g., ft, ea, pr, etc.

e. Quantity Furnished With Equipment (BIIL only). This column indicates the quantity of an item furnished with the equipment.

f. Quantity Authorized (Items Troop Installed or uthorized Only). This column indicates the quantity of the item authorized to be used with the equipment.

g. Illustration (BIIL Oly). This column is divided as follows:

(1) *Figure number.* Indicates the figure number of the illustration in which the item is shown.

(2) *Item number.* Indicates the callout number used to reference the item in the illustration.

Section III. ITEMS TROOP INSTALLED OR AUTHORIZED LIST

(1) SMR code	(2) Federal stock number	(3) Description Ref. No. & Mfr code	(4) Unit of mess	(5) Qty auth
PC	7520-559-9818	CASE, MAINTENANCE AND OPERATIONAL MANUAL	EA	1

Page D-5. Appendix D, Section III, is changed as follows:

Page	Line	Action	1			2	3	4	5	6				7					
			Source maintenance and recoverability code							Federal stock No.	Description	Unit of issue	Qty inc in unit	15 Day organizational maint allowances				Illustrations	
			Source	Maintenance	Recoverability									1-5	6-20	21-50	51-100	Figure No.	Item or symbol No.
D-6	1	Ch cols 2 and 3	P	O		5305-269-3211	Section III – REPAIR PARTS FOR ORGANIZATIONAL MAINTENANCE Group 02 – WATER PURIFICATION SCREW, MACHINE MS90725-60 (96906)												
D-6	12	Ch col 2	P	O		4730-230-1996	NIPPLE ***												

By Order of the Secretary of the Army:

BRUCE PALMER, JR.
General U.S. Army
Acting Chief of Staff

Official:

VERNE L. BOWERS,
Major General, United States Army,
The Adjutant General.

Distribution:

To be distributed in accordance with DA Form 12-25A (qty block No. 177), Operator requirements for Water Purification.

*U.S. GOVERNMENT PRINTING OFFICE: 1972-769609/96

TECHNICAL MANUAL }
 NO. 5-4610-210-14 }

HEADQUARTERS
 DEPARTMENT OF THE ARMY
 WASHINGTON, D. C., 12 June 1971

**OPERATOR, ORGANIZATIONAL, DIRECT AND GENERAL
 SUPPORT MAINTENANCE MANUAL, INCLUDING REPAIR
 PARTS AND SPECIAL TOOLS LIST**

**HYPOCHLORINATION UNIT, WATER PURIFICATION,
 FRAME MOUNTED, WATER DRIVEN, 100 GPM (WALLACE
 AND TIERNAN MODEL A-506111) FSN 4610-880-0154**

Current as of 3 May 1971

		Paragraph	Page
CHAPTER	1. INTRODUCTION		
Section	I. General	1-1	1-1
	II. Description and data	1-5	1-1
CHAPTER	2. OPERATING INSTRUCTIONS		
Section	I. Service upon receipt of materiel	2-1	2-1
	II. Movement to a new worksite	2-3	2-4
	III. Controls and instruments	2-5	2-4
	IV. Operation under usual conditions	2-7	2-5
	V. Operation under unusual conditions	2-12	2-11
CHAPTER	3. ORGANIZATIONAL MAINTENANCE INSTRUCTIONS		
Section	I. Repair parts, special tools, and equipment	3-1	3-1
	II. Preventive maintenance checks and services	3-3	3-1
	III. Troubleshooting	3-5	3-3
	IV. Organizational maintenance procedures	3-7	3-3
CHAPTER	4. DIRECT AND GENERAL SUPPORT MAINTENANCE INSTRUCTIONS		
Section	I. Repair parts, special tools and equipment	4-1	4-1
	II. Troubleshooting	4-3	4-1
CHAPTER	5. REPAIR INSTRUCTIONS		
Section	I. Hypochlorinator assembly	5-1	5-1
	II. Water control and measurement	5-5	5-8
APPENDIX	A. REFERENCES		A-1
	B. MAINTENANCE ALLOCATION CHART		B-1
	c. BASIC ISSUE ITEMS LIST		C-1
	D. REPAIR PARTS AND SPECIAL TOOLS LIST		
		Listing Page	Illus Fig
Section	I. Introduction	D-1	
	II. Prescribed load allowance	D-4	
	III. Repair parts for organizational maintenance	D-5	

***This manual supersedes TM 5-4610-210-14, 24
 November 1969, including all changes.**

		Listing Page	Illus Fig	
Group	01.	Water meter assembly	D-4	
	02.	Water purification	D-4	D-1, D-3
	03.	Miscellaneous	D-4	D-4, D-5, D-6, D-8
Section	IV.	Special tools, test and support equipment. (Not Applicable)		D-9
	V.	Repair parts for direct and general support maintenance.	D-9	
Group	01.	Water meter assembly	D-9	D-1-D-3
	02.	Water purification	D-10	D-4-D-8
	03.	Miscellaneous	D-16	D-9
Section	VI.	Special tools, test and support equipment (Not Applicable)		
	VII.	Federal stock number and reference number cross- reference to figure and item number	D-19	
INDEX				1-1

LIST OF ILLUSTRATIONS

<i>Number</i>	<i>Title</i>	<i>Page</i>
I-1	Portable automatic hypochlorination unit, right-front view.	1-2
1-2	Portable automatic hypochlorination unit, left-rear view.	1-3
2-1	Installation of separately packed components	2-2
2-2	Flow chart.	2-3
2-3	Controls and instruments.	2-5
2-4	Preparation for starting	2-6
2-5	operation of equipment	2-9
2-6	Treatment chart	2-10
3-1	Water meter and register box assemblies, removal and installation	3-4
3-2	Register box, disassembly and reassembly.	3-5
3-3	Hypochlorinator assembly, removal and installation.	3-6
3-4	Hypochlorinator pumping head diaphragm, removal and installation.	3-7
3-5	Adjustment of diaphragm	3-8
3-6	Solution valve body, poppet valves and valve seats, removal and installation.	3-9
3-7	Range adjusting and water pressure regulating valve, removal and installation.	3-10
3-8	Water pressure regulating valve separation.	3-11
3-9	Flow controller and balancing water valve, removal and installation.	3-12
5-1	Hypochlorinator disassembly and reassembly.	5-3
5-2	Flow controller, disassembly and reassembly.	5-6)
5-3	Balancing water valve, disassembly and reassembly.	5-7
5-4	Range adjusting valve, disassembly and reassembly.	5-9
5-5	Water meter assembly, disassembly and reassembly.	5-10
5-6	Water pressure regulating valve disassembly and reassembly.	5-11
D-1	Water meter	D-20
D-2	Extension case, cross section	D-21
D-3	Register box	D-22
D-4	Hypochlorinator	D-23
D-5	Flow controller	D-24
D-6	Balancing water valve	D-25
D-7	Range adjusting valve	D-26
D-8	Pressure regulating valve	D-27
D-9	Water purification unit.	D-28

CHAPTER 1

INTRODUCTION

Section 1. GENERAL

1-1. Scope

a. These instructions are published for the information and guidance of personnel to whom the Portable Hypochlorination Unit is issued. Information is provided on the operation, preventive maintenance checks and services, and organizational, direct and general support maintenance of the equipment, accessories, components and attachments.

b. Number in parentheses on illustrations indicate quantity. Numbers preceding nomenclature callouts on illustration indicate the preferred maintenance sequence.

1-2. Forms and Records

a. DA Forms and Records used for equipment maintenance will be only those prescribed in TM 38-750,

b. Report of errors, omissions, and recommendations for improving this publication by the individual user is encouraged. Reports should be submitted on DA Form 2028, Recommended Changes to Publications, and forwarded direct to Commanding General, U. S. Army Mobility Equipment Command, ATTN: AMSME-MPP, 4300 Goodfellow Boulevard, St. Louis, Mo, 63120.

1-3. Administrative Storage

Refer to TM 740-90-1 for information on the administrative storage of this equipment.

1-4. Destruction of Army Materiel to Prevent Enemy Use

Refer to TM 750-244-3 for information on the destruction of this equipment to prevent enemy use.

Section II. DESCRIPTION AND DATA

1-5. Description

a. The portable automatic hypochlorination unit (fig. 1-1 and 1-2), is designed to accomplish automatic chlorination. Where the rate of flow of water being treated is likely to vary, automatic chlorination is essential if a constant chlorine residual is to be maintained. In this process, the chlorinator rate of feed is automatically changed to suit the flow of water under treatment. If the water flow increases, the chlorine application increases proportionately. Conversely, if the water flow decreases, the chlorine application decreases proportionately. In this way, each gallon of treated water receives the same amount of chlorine and, if the character of the water remains constant, a constant chlorine residual results.

b. The unit is capable of treating water flow rates from 2 to 100 gallons per minute (gpm), and will automatically proportion the chlorine feed accurately over a range of 10 to 1 for any one setting of the range adjusting valve. If for instance, the apparatus is adjusted to treat a maximum flow of 100 gpm, it will proportion accurately down to 10 gpm. If the maximum setting is made for a flow of 20 gpm, accurate results will be obtained down to 2 gpm.

c. The main components of the hypochlorination

unit are a hydraulically operated hypochlorinator, a water meter, a pressure regulating valve, and a manual range adjusting valve (globe valve). The hypochlorinator pumps hypochlorite solution into the water under treatment at a rate which is governed by the speed of the water meter. Since the speed of the water meter is always directly proportional to the water flow being treated, the chlorine application is also proportional to the water flow.

d. The water flow meter is operated by a small flow of water which is diverted from the main line by means of the manual range adjusting valve. When water flows through the valve (fig. 2-2), the pressure on the discharge side of the valve is lower than that on the inlet side by the amount of friction loss created by the valve. For any given setting of the valve, the pressure difference will increase as the main flow increases and vice versa. Since the pressure difference is applied to the water meter, the flow through the meter varies in direct proportion to the flow through the main. The water pressure regulating valve maintains a water pressure of at least 10 pounds per square inch (psi) in the system so that the hypochlorinator can be operated satisfactorily.

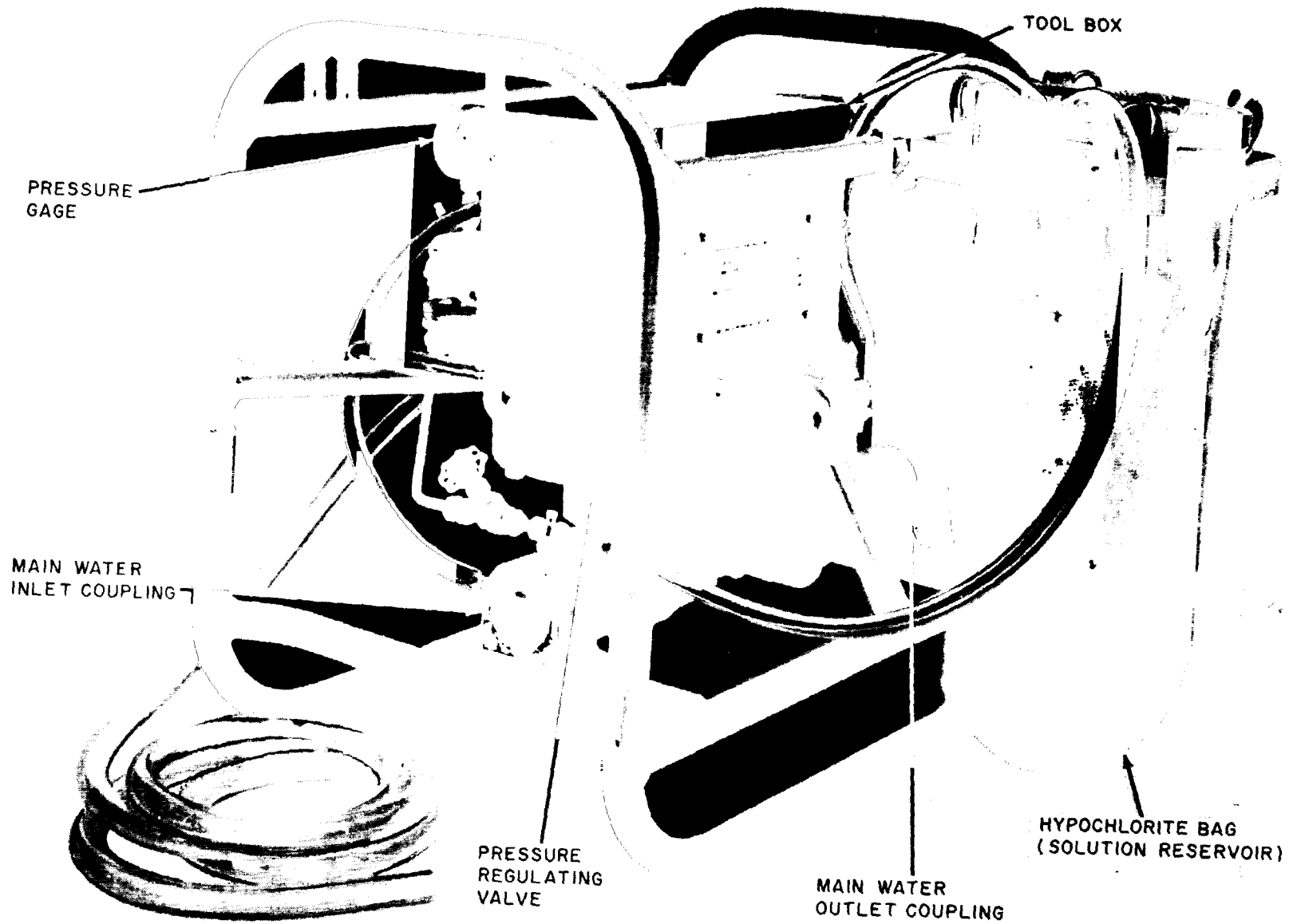

ME 4610-210-14/1-1

Figure 1-1. Portable automatic hypochlorination unit, right-front view.

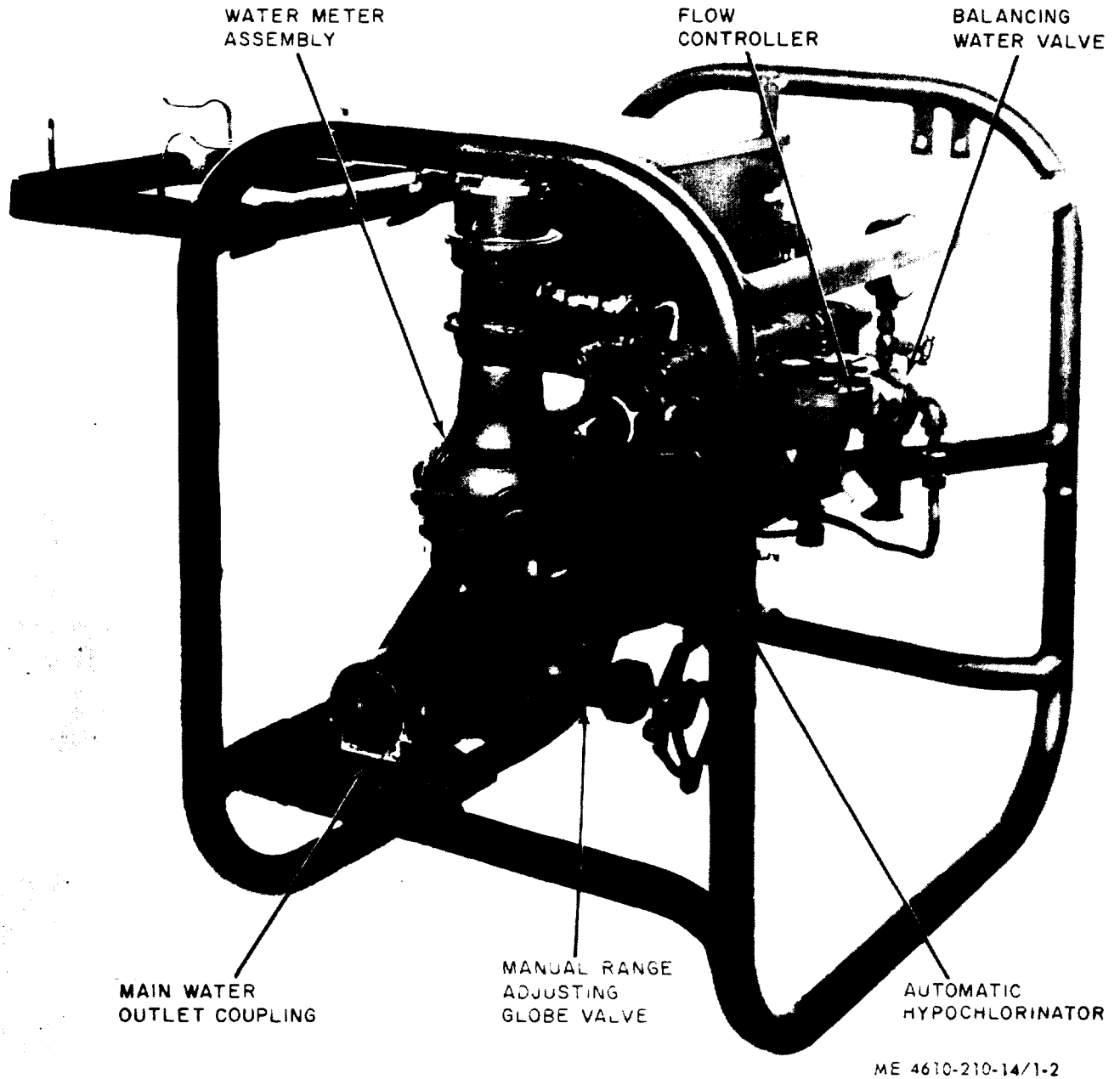

ME 4610-210-14/1-2

Figure 1-2. Portable automatic hypochlorination unit, left-rear view.

1-6. Identification and Tabulated Data

a. Identification. The portable automatic hypochlorination unit has only one identification plate. The information contained on the plate includes the model number, capacities, weight, height, width, length, and manufacturer's name. The plate is fastened to the tool box.

b. Tabulated Data.

(1) *Hypochlorinator.*

Manufacturer. Wallace and Tiernan, Inc.
 Model A-416121

(2) *Balancing water valve.*

Manufacturer. Wallace and Tiernan, Inc.
 Model. UXA-5262

(3) *Flow controller.*

Manufacturer. Wallace and Tiernan, Inc.
 Model. UXA-15948

(4) *Meter extension case.*

Manufacturer. Wallace and Tiernan, Inc.
 Model. U-13896

(5) *Water pressure regulating valve (2 inch).*
Manufacturer Wallace and Tiernan, Inc.
Model U-7792

(6) *Range adjusting valve (2 inch).*
Manufacturer Wallace & Tiernan Division
Pennwalt Corp.
Model UXB-7864

(7) *Shipping dimensions.*
length 25 inches
Width 19½ inches
Height 25½ inches
Weight 270 pounds

(8) *Performance.*
Maximum water flow
treated 100 gpm
Minimum water flow
treated 2 gpm

Automatic proportioning
range 10 to 1
Maximum hypochlorinator
pumping rate 60 gallons per 24 hours at 12
strokes per minute
Maximum allowable water
pressure 125 psi
Minimum allowable water
pressure 10 psi

(9) *Capacities.*
Hypochlorite bag5 gallons

1-7. Difference in Models

This manual covers Model A.506111 Portable Automatic Hypochlorinator Unit only. No differences exist between models covered by this manual.

OPERATING INSTRUCTIONS

Section I. SERVICE UPON RECEIPT OF MATERIEL

2-1. Inspecting and Servicing the Equipment

a. Inspection.

(1) Check unit for breaks, cracks, or other possible shipping damage.

(2) Check to determine if all attachments required for operation are present and in an operating condition.

b. Servicing.

(1) Thoroughly clean all surfaces with an approved cleaning solvent. Wash with potable water.

(2) Perform required preventive maintenance checks and services.

2-2. Installation

a. Refer to figure 2-1 and install the component as follows:

(1) Lift reservoir support from stowed position so that it lies parallel to floor.

(2) Insert hypochlorite bag (solution reservoir) and attach straps to hooks on reservoir support.

(3) Attach one end of inlet hose (4 foot length) to petcock adapter and place other end in hypochlorite bag (solution reservoir).

(4) Attach strainer to one end of hypochlorinator suction hose (5½ foot length) and place in hypochlorite bag (solution reservoir), attach other end of hose to hypochlorinator suction fitting.

(5) Attach one end of waste water hose (8 foot length) to hypochlorinator adapter. Place the other end at a point away from the apparatus.

(6) Connect hypochlorinator discharge hose (20-inch length) between hypochlorinator discharge fitting and hose connector at inlet coupling.

b. The unit is equipped with 2-inch female pipe connections at the inlet and outlet that can be connected directly into main water line or the line to be treated. In some cases, adapters are furnished to permit a 3-inch hose inlet connection and a 4-inch pipe discharge connection. The outlet connection must be connected to the line which runs to the storage tank or distribution system. Figure 2-2 illustrates water flow after installation of unit into main line.

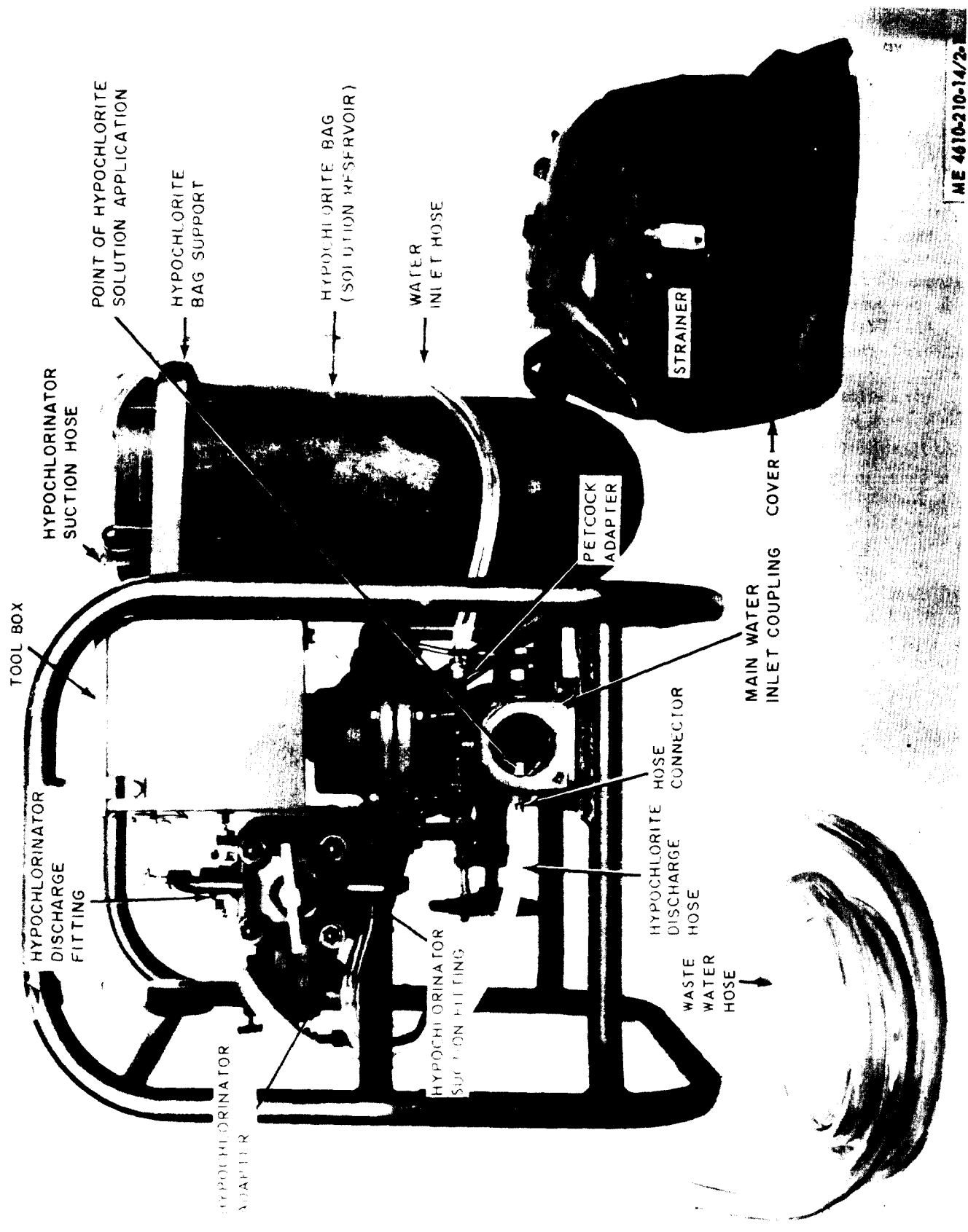
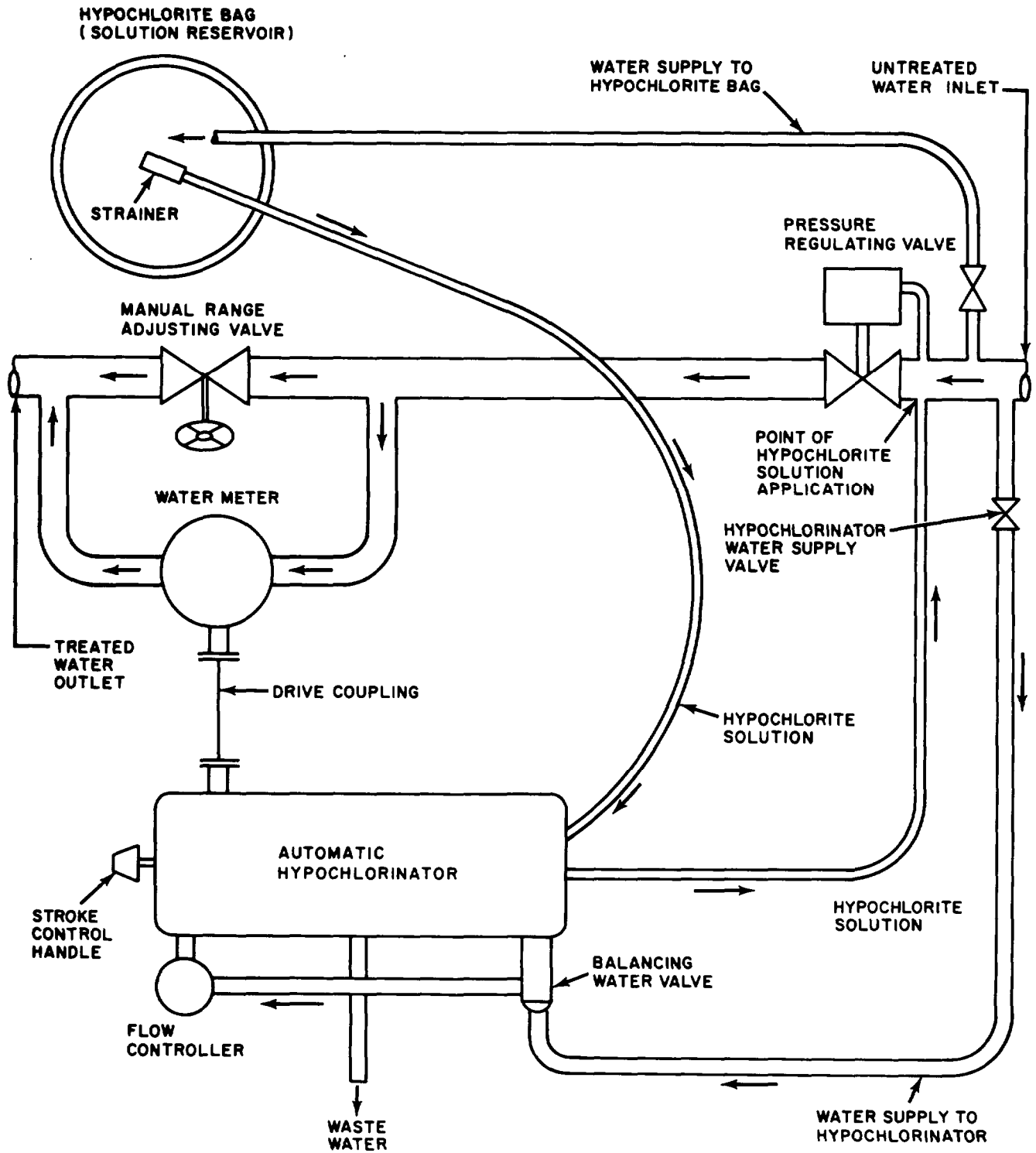

Figure 2-1. Installation of separately packed components.



ME 4610-210-14/2-2

Figure 2-2. Flow chart.

Section II. MOVEMENT TO A NEW WORKSITE

2-3. Dismantling for Movement

The only dismantling required is the removal and stowing of the hypochlorite bag and the dropping of the hypochlorite bag support. When necessary to move the water purification unit to a new worksite, it is shipped as a complete unit. After performing the required preventive maintenance checks and

services, position the unit on the transporter (truck, flatcar, etc.). Block and tie down securely. For long distance moving cover unit with cover provided.

2-4. Reinstallation After Movement

Refer to paragraph 2-2 to reinstall the unit after movement to a new worksite.

Section III. CONTROLS AND INSTRUMENTS

2-5. General

This section describes the various controls and instruments and provides the operator / crew sufficient information to insure proper operation of the hypochlorination unit.

2-6. Controls and Instruments (fig. 2-3)

a. Stroke Control. The setting of the stroke control determines the length of stroke of the pumping shaft and thereby the quantity of hypochlorite solution pumped per stroke. For maximum length of stroke the pointer is set at 10 on the dial. With the pointer set at 5, the stroke length is one-half maximum ; at 7, it is seven-tenths maximum, etc.

b. Flow Controller. The flow controller is a spring-loaded diaphragm and needle valve which operates to maintain a fixed flow rate through the valve, thus stabilizing the force applied to the automatic hypochlorinator valve diaphragm (fig. 2-5) during the pumping cycle.

c. Hypochlorinator Water Supply Valve. This valve serves to shut off the water supply to the hypochlorinator when maintenance must be performed. During normal operation, this valve must be wide open at all times.

d. Range Adjusting Valve (Globe Valve). This

valve creates a pressure drop in the main 2-inch water line which may be varied by changing the valve setting. Turning the valve handle to the right increases the pressure drop and turning to the left decreases the pressure drop. For a given water flow through the unit, the setting of this valve governs the speed of the hypochlorinator.

e. Water Meter Register. The water meter register is located on top of the water meter. The register totalizes the amount of the water flowing through the bypass line. By observing the time required for a certain quantity of water to pass through the meter, the flow rate in the bypass may be determined. For example, if 50 gallons pass through the meter in 10 minutes, the average bypass flow rate is 50 divided by 10 or 5 gpm. The flow through the bypass should not exceed 10 gpm, which is equivalent to the maximum hypochlorinator operating speed of 12 strokes per minute.

f. Water Pressure Gage. The water pressure gage is located on top of the balancing water valve. The gage indicates the hypochlorinator operating water pressure. The gage reading should always be 10 pounds per square inch or greater.

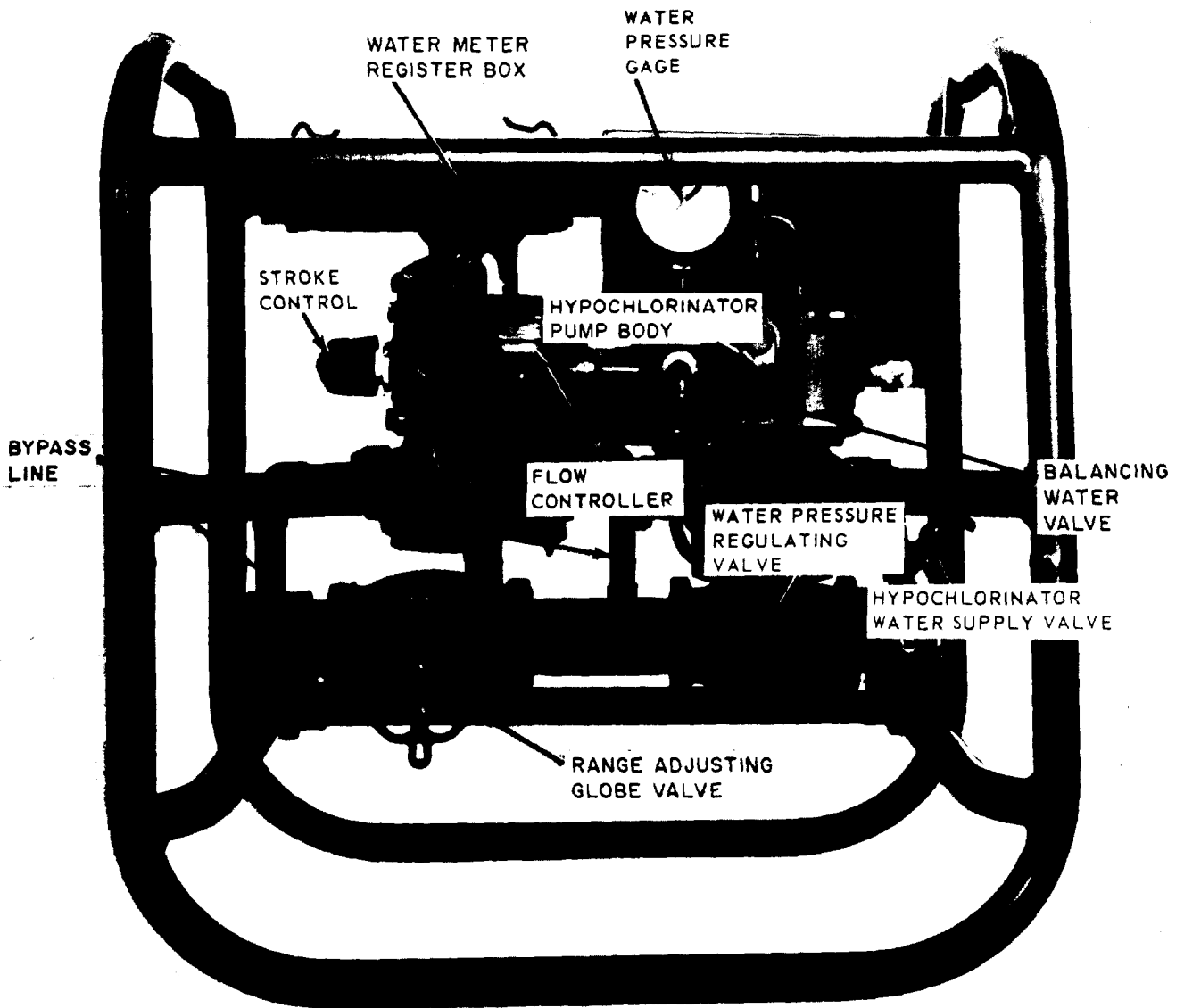

ME 4610-210-14/2-3

Figure 2-3, Control and instruments.

Section IV. OPERATION UNDER USUAL CONDITIONS

2-7. General

a. The instructions in this section are published for the information and guidance of personnel responsible for the operation of the hypochlorination unit.

b. The operator must know how to perform every operation of which the hypochlorination unit is capable. This section gives instructions on starting and stopping the hypochlorination unit. Also included are instructions on operation of the unit, and

on coordinating the basic motions to perform the specific task for which the equipment is designed. Since nearly every job presents a different problem, the operator may have to vary given procedures to fit the individual job.

2-8. Starting

a. *Preparation for Starting* (fig. 2-4).

(1) Perform the inspection and service referenced in paragraph 2-1 and table 3-1.

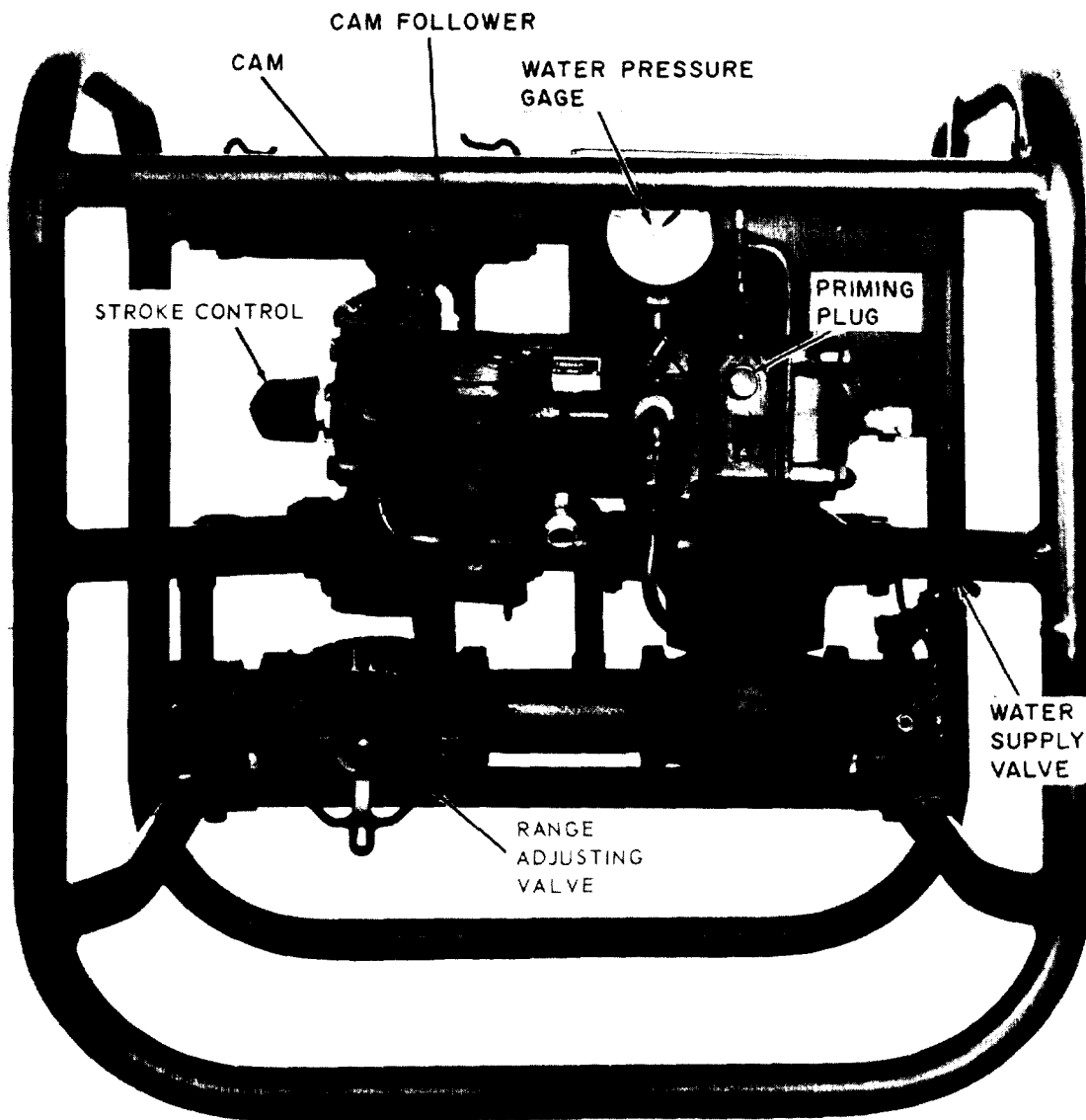

ME 4610-210-14/2-4

Figure 2-4. Preparation for starting.

(2) Make up hypochlorite solution in reservoir by adding high test hypochlorite powder to clear water. If maximum flow to be treated is near 100 gpm make up a 1 percent solution (10 ounces of hypochlorite powder to 5 gallons of water). If maximum anticipated flow is around 50 gpm, start with a 0.5 percent solution (5 ounces of hypochlorite powder to 5 gallons of water). Be sure that strainer is installed on end of hypochlorinator suction hose.

(3) Set hypochlorinator stroke control so that indicator pointer is at 10 on dial.

(4) Open water supply valve in hypochlorinator water supply line. Open range adjusting

valve wide. Check to see that water pressure gage registers at least 10 psi.

b. Starting. Starting the hypochlorination unit is only a matter of placing the unit into the water line that is to be treated and allowing the water to pass through. Inlet and outlet markings must be observed. After installation, proceed as follows:

(1) Decide what maximum flow is to be treated, and, if possible, produce this flow through apparatus. Maximum flow should not exceed 100 gpm. Adjust range adjusting valve so that hypochlorinator runs at a speed of 12 strokes per minute when maximum flow is flowing through apparatus. Strokes can be counted by observing the

cam follower. Each time the cam follower passes over the tip of a cam lobe, a stroke has been completed.

(2) If maximum anticipated flow cannot be obtained at time of adjustment, it will be necessary to do some calculation. In general, the unit must be set so that the number of strokes per minute divided by 12 equals actual flow at time of adjustment divided by maximum flow to be treated. This relationship is expressed as follows:

$$\text{No. Strokes} = \frac{\text{Existing Flow}}{12} \times \text{Maximum flow to be treated}$$

Assume, for example, that maximum flow to be treated is 80 gpm, but actual flow is only 60 gpm when unit is being adjusted. Since 60 is three-quarters of 80, then the range adjusting valve would be set to produce 9 strokes per minute. With this valve setting, hypochlorinator would operate at 12 strokes per minute when flow increases to 80 gpm.

(3) Check to see that hypochlorinator is primed. Usually the apparatus will be self-priming. If difficulty is experienced, the process may be aided by bleeding air out of the pump block by means of the priming plug (fig. 2-4). The plug should be unscrewed during pumping (forward) stroke and quickly tightened at beginning of suction (backward) stroke. If unit cannot be primed, check hypochlorinator suction line for air leaks.

(4) After hypochlorinator has been in operation for a short time; take a chlorine residual test. Refer to TB 3-6630-201-10 for proper procedure for making test.

(5) If residual reading is low, increase strength of hypochlorite solution. If reading is high, set stroke control at "8" on dial, let unit run for a while, and take another residual test. If reading is still high, reduce stroke control setting to "6". If, at a setting of "6" residual is still too high, dilute hypochlorite solution slightly and repeat test. Repeat this process until a satisfactory residual is obtained with a stroke control setting of between "6" and "10".

NOTE

The chlorine residual in the treated water should be prescribed by the area medical officer as indicated after 10-minute contact.

(6) When residual test has been satisfactorily completed, unit may be operated with little attention until level of solution in reservoir drops to within 2 or 3 inches of strainer. A new batch of solution must be made when this occurs. When stroke control is set at "10" and hypochlorinator is running at 12 strokes per minute, unit will pump 60 gallons of solution in 24 hours. At a setting of "6" on stroke control and a speed of 12 strokes per

minute, unit will pump 36 gallons of solution in 24 hours. Intermediate settings on stroke control will produce pump page rates proportional to setting. Pump page is also directly proportional to number of strokes per minute.

(7) Chlorine residual test should be made at frequent intervals to see that proper residual is being maintained. Over a period of time, character of water may change and chlorine requirement may vary slightly. It may be necessary to change stroke control setting from time to time to hold required residual.

2-9. Stopping

The shutdown of the hypochlorination unit is more or less automatic. The hypochlorinator will stop when water stops flowing through the main line under treatment. It is advisable to remove the hypochlorinator suction hose and strainer from the solution reservoir when the unit is not in operation. Examine balancing water valve strainer (fig. 5-3) and clean if necessary.

2-10. Principles of Operation of Equipment (fig. 2-5)

a. Hypochlorinator.

(1) The hypochlorinator is a hydraulically-operated displacement pump in which a diaphragm replaces the conventional piston. A controlled flow of water is admitted through a flow controller to a chamber behind the valve diaphragm. If the cam roller is on a low portion of the cam, the pilot valve is open and no pressure exists behind the valve diaphragm. As the cam rotates, the cam roller is pushed forward and the lower end of the pilot valve lever closes the pilot valve. Pressure then builds up behind the valve diaphragm; enough force is developed to overcome the force of the return spring. The pump shaft and pumping head diaphragm move forward to execute the pumping stroke. During this process, the suction poppet valve is closed, the discharge poppet valve is open, and solution is pumped out of the space between the head diaphragm and pump body.

(2) The pumping stroke continues until the cam roller passes over the tip of a cam lobe. The follower immediately drops down to a low portion of the cam, the pilot valve opens, and pressure is relieved from behind the valve diaphragm. The return spring then pushes the pump shaft back to open the balancing water chamber and to perform the suction stroke. During this process the suction poppet is open, the discharge poppet valve is closed, and a charge of hypochlorite solution is drawn into the pump body.

(3) It will be seen from this discussion that the number of strokes per minute which are executed by the hypochlorinator is determined by the speed at which the cam rotates. The cam is paced from

the water meter and the speed at which the hypochlorinator pumps will be in direct proportion to the amount of water passing through the meter. The pumpage will vary to suit the flow of water being treated.

b. Balancing Water Valve.

(1) The main elements of the balancing water valve are a diaphragm, a valve seat rigidly fastened to the diaphragm, a valve stem, and a spring. The discharge connection from the valve is connected to a balancing chamber behind the pumping head diaphragm. The hypochlorinator pump shaft is hollow and is also drilled. Water from the balancing chamber can escape through the shaft to the waste area during the suction stroke when the valve at the driving yoke end of the shaft is open. It should be noted that the balancing valve stem can never completely shut off the water flow through the balancing valve seat.

(2) During the hypochlorinator suction stroke, the valve on the end of the pump shaft is open. No pressure exists in the balancing chamber behind the pumping head diaphragm. Water pressure on the inlet side of the balancing diaphragm pushes the diaphragm forward so that the valve seat is against the valve stem. Under these conditions, the only flow through the valve is the leakage past the stem. When the hypochlorinator pressure (forward) stroke begins, the driving yoke integral valve seat moves against the open end of the pump shaft, thus sealing the hypochlorinator balancing water chamber. The leakage through the balancing valve is then trapped and pressure begins to build up in the balancing chamber and therefore, on the discharge side of the balancing valve diaphragm. When the discharge pressure on the diaphragm approaches the pressure on the inlet side of the diaphragm, the diaphragm and the valve seat are pushed away from the valve stem by the spring. The balancing valve then passes enough water to maintain a pressure in the balancing chamber behind the main diaphragm about equal to the pressure which exists in the hypochlorinator discharge line. The foregoing operations take place rapidly so that pressure is built up in the balancing chamber almost immediately after the beginning of the pressure stroke.

c. Flow Controller. The flow controller is a spring-loaded diaphragm and needle valve. When an increase in inlet water flow occurs, the flow controller diaphragm moves the needle valve toward its seat, thus causing a reduction of flow at the valve outlet.

d. Water Pressure Regulating Valve (fig. 2-3). The water pressure regulating valve has a spring-loaded diaphragm which holds the valve closed until a pressure of at least 10 psi exists under the diaphragm.

2-11. Preparation of Sterilizing Solution

a. Hypochlorite Solution. The hypochlorinator is designed to pump hypochlorite solution and in most cases, best results will be obtained by making solution from high-test hypochlorites which are dry powders, usually conveniently packed in small containers. Normally, only a part of the hypochlorite in a can will be used for each batch of solution. It is extremely important that the excess chemical be stored in dry airtight containers in a dry storage space.

b. Strength of Solution.

(1) When the portable automatic hypochlorination unit is first placed in operation on water whose chlorine requirements are unknown, a certain amount of experimenting will be necessary. This is necessary to determine the hypochlorite solution strength which will best accomplish the desired results. Two factors determine the amount of chlorine which is added to a given volume of water when it is treated with hypochlorite solution. One is the volume of hypochlorite solution used, and the other is the strength of the solution. For example, 60 gallons of 0.5 percent hypochlorite solution contains the same amount of chlorine (2.5 pounds) as 30 gallons of 1.0 percent solution. If the volume of water being treated requires 2.5 pounds of chlorine per day to produce the required chlorine residual; it may be treated with either 60 gallons per day of 0.5 percent solution or 30 gallons per day of 1.0 percent solution. At a speed of 12 strokes per minute, the hypochlorinator will pump 60 gallons of solution per day when the stroke control is set at "10" on the dial. It will pump 30 gallons per day with a setting of "5" on the dial. It is more desirable to operate the hypochlorinator with a weak solution and a long stroke rather than with a strong solution and a short stroke.

(2) A 1.0 percent hypochlorite solution contains 1 part by weight of available chlorine in 100 parts by weight of solution. In calculating solution strengths, it should be noted that 1 ounce of calcium hypochlorite powder contains 0.7 of an ounce of available chlorine. For field operation, assume that the addition of 10 ounces of hypochlorite powder to 5 gallons of water will produce a 1.0 percent hypochlorite solution.

(3) Figure 2-6 gives the relationship between the flow of water to be treated and the volume and strength of hypochlorite solution required to produce various chlorine treatments. In using the chart, remember that the figures labelled PPM (part per million) refer to chlorine dosage and not chlorine residual. "Dosage" indicates the total amount of chlorine added to the water. "Residual" refers to the amount of chlorine remaining in the water after the chlorine and water have been in

contact for a specified time (10 minutes). The dosage is determined from the calculation and based on the fact that 8.3 pounds of chlorine per million gallons of water represent one part of chlorine in a million parts of water. Chlorine residual is determined by measurement by color comparator and is the final check on proper chlorination.

(4) The use of the chart is most readily explained by taking an example. Suppose that it is desired to add 3 ppm of chlorine to a water flow of 80 gpm. on the upper left-hand portion of the chart, we find the line corresponding to 80 gpm and run horizontally to the line marked 3 ppm (note

dotted line 1. A vertical line dropped from the intersection to the lower half of the chart gives the volumes of various solutions necessary to achieve a 3 ppm treatment. We find that the treatment can be obtained with about 18 gallons per day of 2 percent solution : With 35 gallons per day of 1 percent solution; or with about .58 gallons per day of .6 percent solution. If the hypochlorinator runs at a speed of 12 strokes per minute, it will pump 18 gallons per day when the stroke control is set at 3; 36 gallons per day at a setting of 6; and 60 gallons per day at a setting of 10.

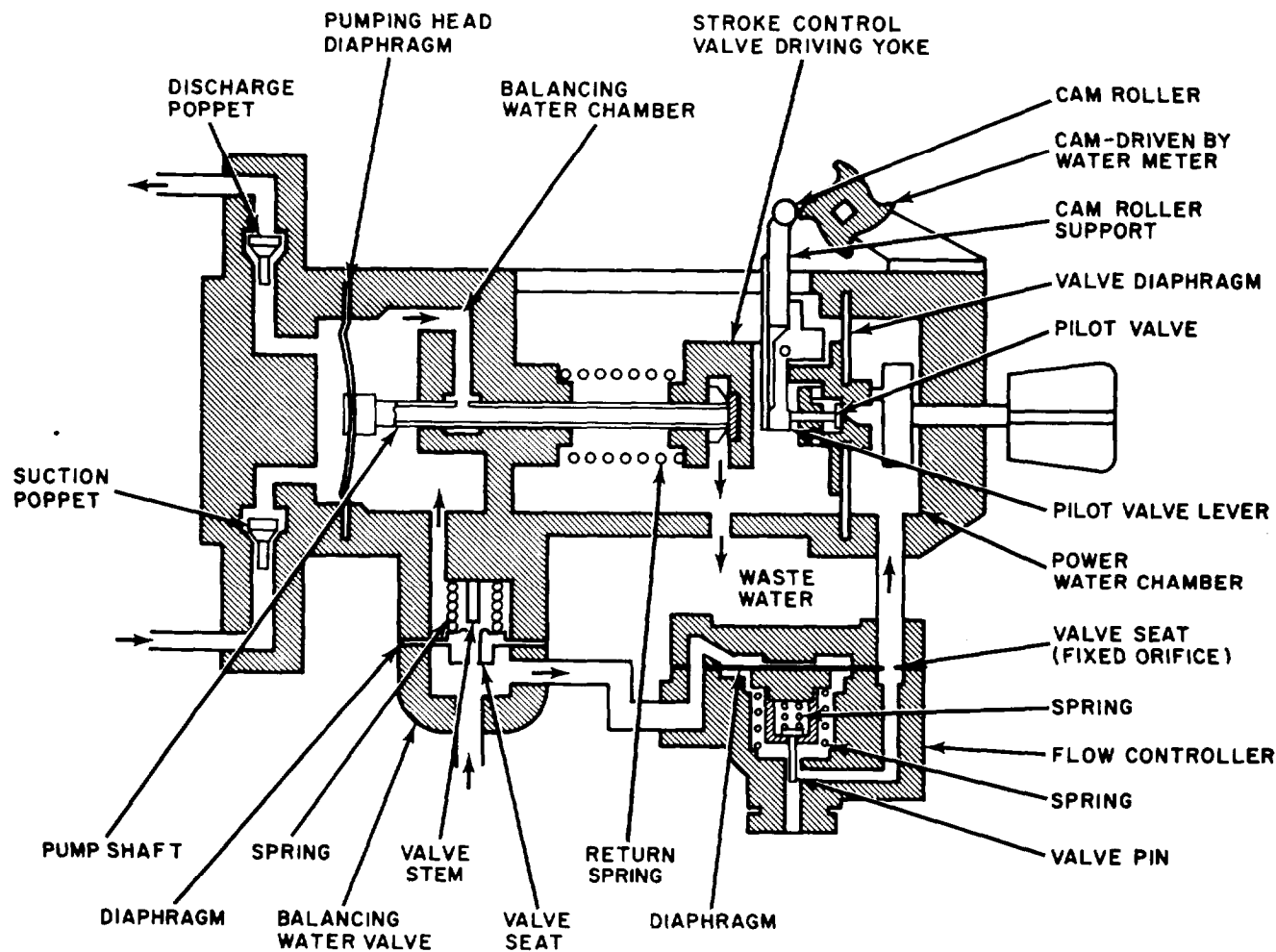

ME 4610-210-14/2-5

Figure 2-5. Operation of equipment.

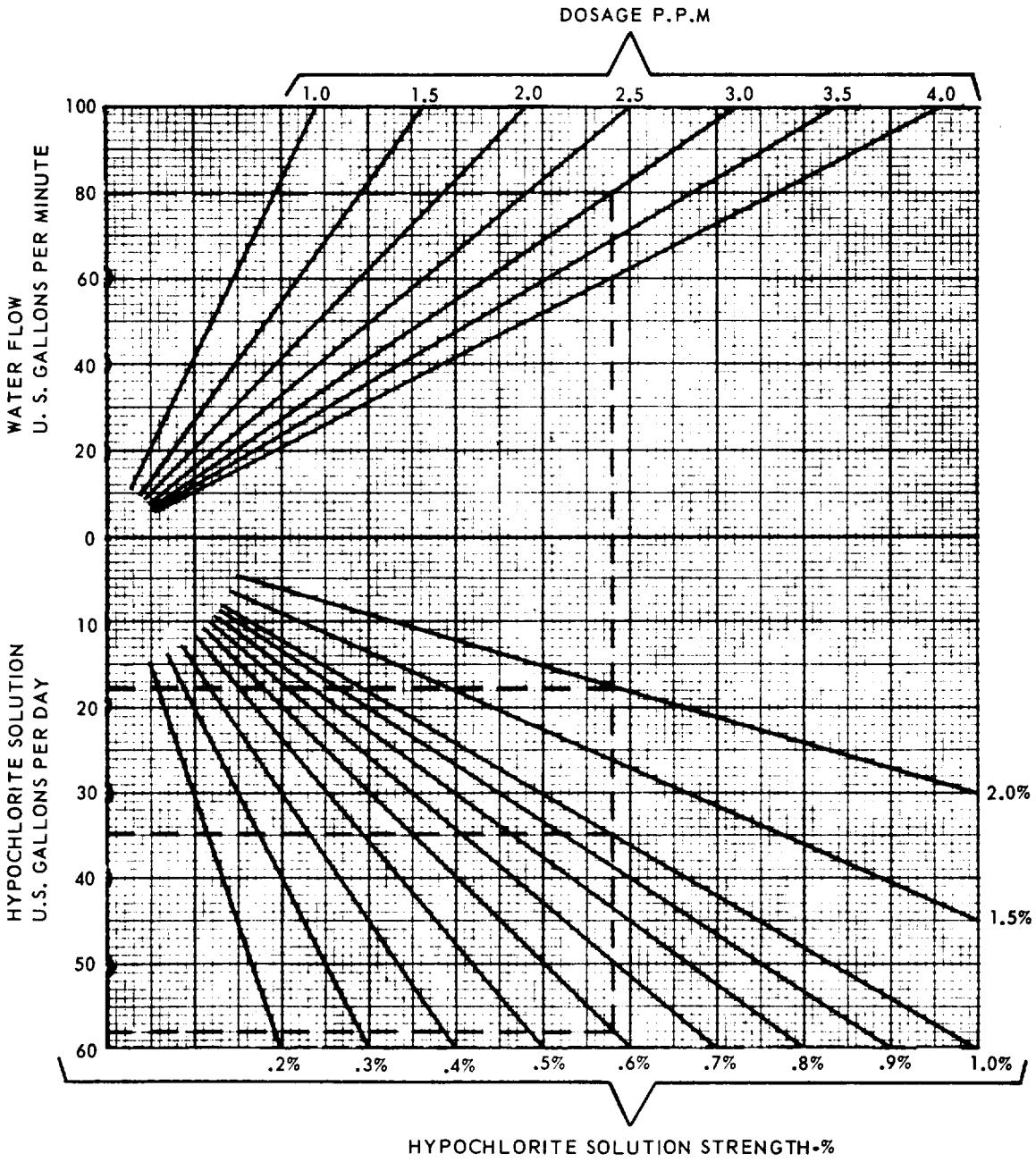

ME 4610-210-14/2-6

Figure 2-6. Treatment chart.

2-12. General

The unit will operate satisfactorily under extremes of heat, rain, high humidity, high altitude, water, mud, rocks, etc.

2-13. Operation in Extreme Cold (Below 0° F (-18° C))

a. When operating the unit where freezing temperatures are likely to be encountered, it is essential that all water be drained from the unit during shutdown periods. It is important that all hypochlorite solution be drained from the hypochlorinator pump body by removing the poppet valves (para 3-14).

b. If at all possible, locate the unit to take advantage of natural barriers that will protect it from the elements. Construct windbreakers and erect tenting.

WARNING

Do not touch metal parts with bare hands during extremely low temperatures.

2-14. Operation in Salt Water Areas

A water supply which is contaminated with salt water is not satisfactory as a drinking water supply. Water containing salt should not be used for preparing hypochlorite solution.

2-15. Operation in Dusty or Sandy Areas

a. Locate the equipment where dust and sand are at a minimum. Erect barriers and tenting to protect the unit from blowing dust or sand. Cover the hypochlorite solution reservoir.

b. Whenever possible, wash the equipment free of dirt and dust. Wet down the immediate area to lessen the amount of blowing sand or dust.

2-16. Hypochlorinator Operation With Hard Water

a. If difficulty is experienced in obtaining proper hypochlorinator operation where hard water conditions are known to exist, it is recommended that the pumping block assembly (fig. 2-3) be removed for cleaning.

b. The formation of a white coating on the hypochlorinator diaphragm, on the hypochlorinator poppet valves, or on the hypochlorinator poppet valve seats, is an indication of the effects of hard water and may bring about improper operation of the hypochlorinator. The coating can easily be removed by soaking the parts in 5 percent hydrochloric acid.

c. When the water used to dilute or mix the sterilizing hypochlorite solution contains what is commonly termed "hardness", it is necessary to observe certain precautions. In order to precipitate as much as possible of the "hardness" before the solution has passed through the hypochlorinator, it is recommended that soda ash, or what is more commonly known as washing soda, be added to the sterilizing solution. This will result in the precipitation of the "hardness", and the precipitate should be allowed to settle to the bottom of the mixing container. The amount of soda ash to be added can best be determined experimentally by observing the precipitate. A slight excess of soda ash is not harmful in any way. Certain types of hardness will precipitate without the washing soda. Where a precipitate is obtained, it is advisable to use two solution containers. The solution should be made up in a container such as a barrel and after the precipitate has formed, the clear solution should be syphoned into the hypochlorite bag on the unit. The precipitate should be disposed of to waste.

ORGANIZATIONAL MAINTENANCE INSTRUCTIONS

Section I. REPAIR PARTS, SPECIAL TOOLS, AND EQUIPMENT

3-1. Tools and Equipment

- a. There are no basic issue tools or repair parts issued with or authorized for the Portable Hypochlorinator Unit.
- b. There are no special tools required to perform organizational maintenance on the unit,

3-2. Maintenance Repair Parts

Organizational maintenance repair parts are listed and illustrated in appendix D of this manual,

Section II. PREVENTIVE MAINTENANCE CHECKS AND SERVICES

3-3. General

To insure that the portable automatic hypochlorinator unit is ready for operation at all times, it must be inspected systematically. Defects must be discovered and corrected before they result in serious damage or failure. The necessary preventive maintenance checks and services to be performed are described in table 3-1. The item numbers indicate the sequence of minimum inspection requirements. Defects discovered during operation will be noted for future correction as soon

as operation ceases. Stop operation immediately if a deficiency is noted which would damage the equipment if operation were continued. All deficiencies and shortcomings will be recorded with the corrective action taken on DA Form 2028 as soon as possible.

3-4. Preventive Maintenance Checks and Services

Refer to table 3-1 to perform the preventive maintenance checks and services on the equipment.

Table 3-1. Preventive Maintenance Checks and Services

Item number	Interval						Item to be Inspected	Procedure	Reference
	Operator			Org.					
	B	D	A	W	M	Q			
1	X						Water piping	Check water piping, hose connections, and tube connections for leaks.	Para 2-9
2	X						Hypochlorite solution reservoir	Check to see that there is an adequate supply of hypochlorite solution in the reservoir. Check for leaks in reservoir.	
3		X					Pressure gage	Check water pressure gage. Pressure should not be less than 10 pounds.	Figure 2-4
4			X				Hoses and strainer	Remove hypochlorite suction hose and strainer from solution reservoir. Clean strainer if necessary.	Figure 2-1
5			X				Hypochlorinator	If freezing weather is anticipated, drain all water from unit. Drain hypochlorite solution from hypochlorinator pump body, poppet valves and hypochlorite bag.	Para 2-14
6 *					X		Hypochlorinator pumping head diaphragm	Check adjustment. Check for holes, cracks, or other damage. If diaphragm is covered with white coating, clean with 5 percent hydrochloric acid.	Para 3-13
7 *					X		Hypochlorinator poppet valves and seats	Remove and check for damage or pitting. If covered with white coating, clean with 5 percent hydrochloric acid.	Para 3-14
8 *					X		Hypochlorinator body	Remove and check for cracks, pitting, or other damage. If covered with white coating, clean with 5 percent hydrochloric acid. Check condition of priming plug and priming gasket.	Para 3-4
9 *					X		Hypochlorinator suction strainer	Inspect strainer and clean if necessary.	Para 2-1
10 *					X		Balancing water valve strainer	Inspect strainer and clean if necessary.	Para 3-17

Section III. TROUBLESHOOTING

3-5. General

This section provides information useful in diagnosing and correcting unsatisfactory operation or failure of the unit and its components.

3-6. Troubleshooting Procedure

Malfunctions which may occur are listed in chart 3-1. Each malfunction stated is followed by a list of probable causes of the trouble. The corrective action recommended is described opposite the probable cause.

Chart 3-1. Troubleshooting

Malfunction	Probable cause	Corrective Action
1. Hypochlorinator cam does not rotate.	a. Water meter defective	a. Replace water meter (fig. 3-1), and refer defective unit to direct support personnel.
	b. Mechanical binding in meter extent ion case or defective overload release.	b. Replace water meter (fig. 3-1), and refer defective unit to direct support personnel.
2. Cam rotates but pump shaft does not move properly.	a. Stroke adjustment set improperly.	a. Reset stroke control (para 2-6).
	b. Insufficient water pressure to hypochlorinator.	b. Clean balancing water strainer (para 3-17). Be sure water supply line is unobstructed.
	c. Stoppage in main connection or discharge line.	c. Clear stoppage.
3. Insufficient quantity of solution delivered. Cam rotates and pump shaft moves properly.	a. Solution below strainer level.	a. Add solution
	b. Suction valve not seating.	b. Refer to direct support personnel.
	c. Discharge valve not seating.	c. Refer to direct support personnel.
	d. Priming plug not closed or defective.	d. Tighten plug or replace gasket.
	e. Valve seats not properly positioned or defective gaskets.	e. Loosen clamp and properly position valve seats. Replace defective gaskets (para 3-16).
	f. Air leak in suction line or fitting.	f. Tighten all connections. Replace line if required.
	g. Pumping head diaphragm damaged.	g. Replace diaphragm (para 3-13).

Section IV. ORGANIZATIONAL MAINTENANCE PROCEDURES

3-7. Toolbox

To remove the toolbox (fig. 2-1), remove the four screws, washers, and nuts that secure the toolbox to the frame. Install the toolbox in the reverse order of removal.

3-8. Cover

To replace the cover (fig. 2-1), simply put it over the unit and fasten the straps.

3-9. Water Pressure Gage

To remove and install the water pressure gage (fig. 2-3). use an open end wrench to turn the gage counterclockwise and remove it from the balancing

valve housing. Install the water pressure gage in the reverse order of removal.

3-10. Water Meter Assembly

a. *Removal and Installation.* Refer to figure 3-1 and perform steps 1 through 4 to remove and install the water meter assembly. Install in the reverse order of removal.

b. *Cleaning and Inspection.*

(1) Using warm water and soap, clean the water meter assembly and dry thoroughly.

(2) Inspect assembly for cracks, breaks, or other damage. Report any damage to direct support maintenance personnel.

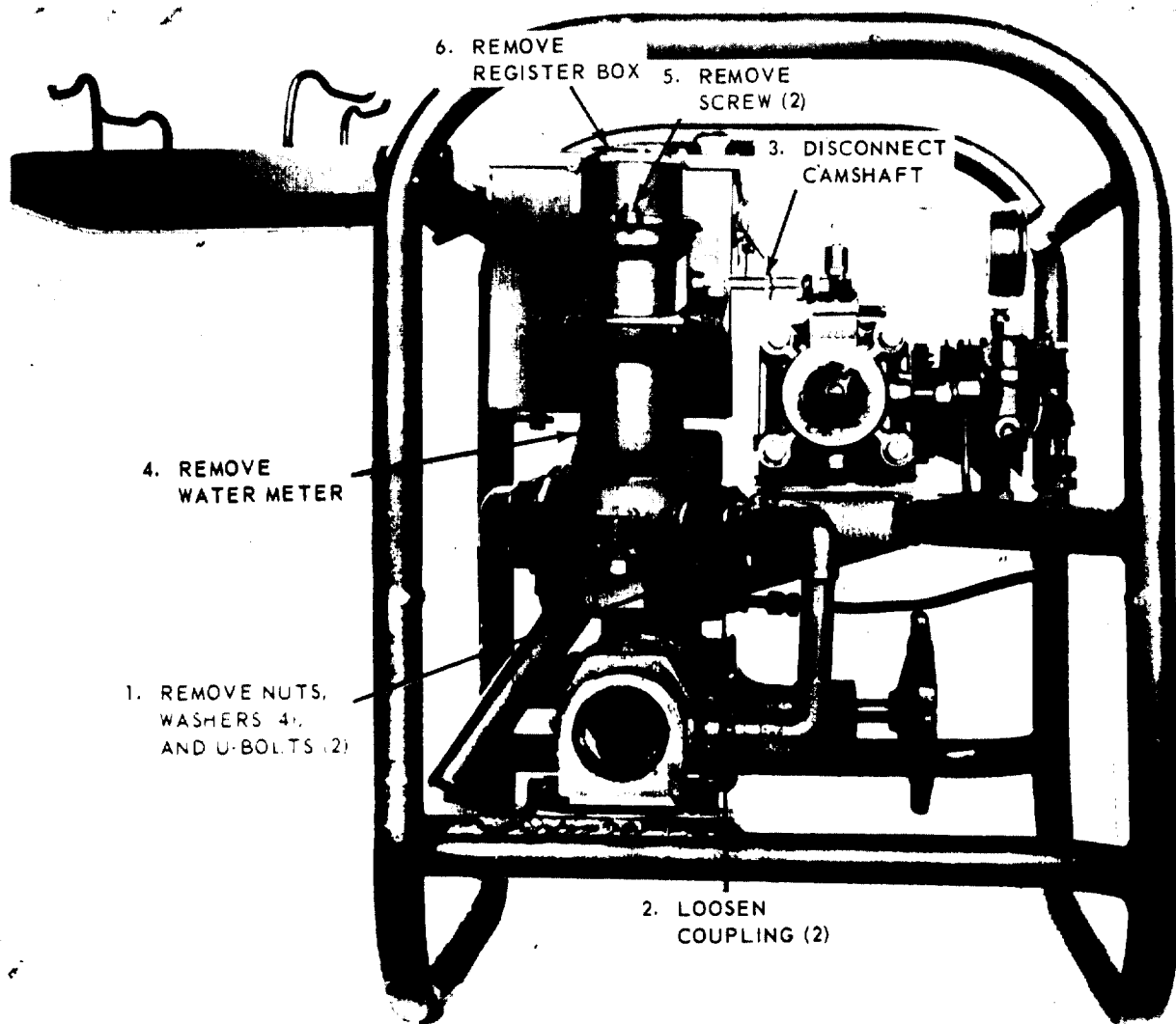

ME 4610-210-14/3-1

Figure 3-1. Water meter and register box assemblies. removal and installation.

3.11. Register Box Assembly

a. Removal and Installation. Refer to figure 3-1 and perform steps 5 and 6 to remove and install the register box assembly.

b. Disassembly and Reassembly. Refer to figure 3-2 to disassemble and reassemble the register box assembly.

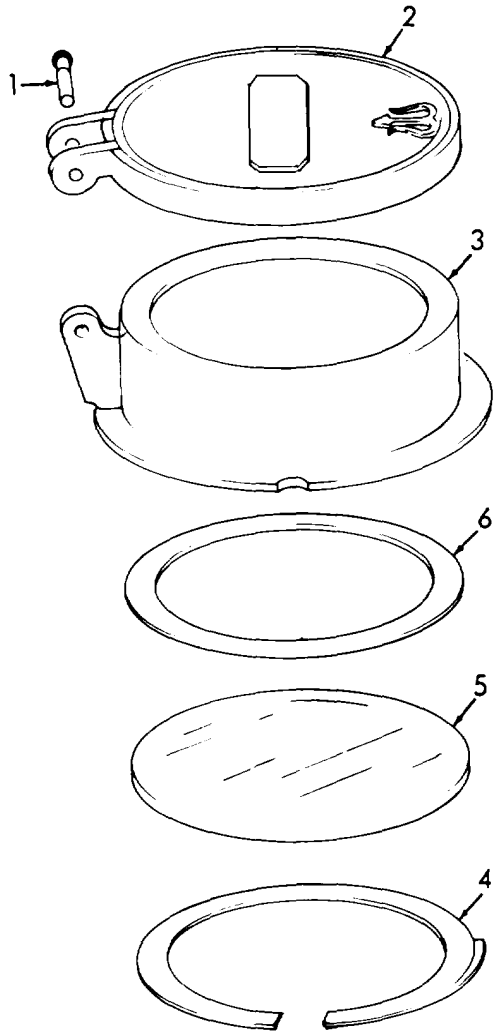

ME 4610-210-14/3-2

- 1 Pin
- 2 Cover
- 3 Box
- 4 Ring
- 5 Window
- 6 Washer

Figure 3-2. Register box. disassembly and reassembly.

3-12. Hypochlorinator Assembly

a. Removal. Disconnect hypochlorinator suction, discharge, and waste water hoses; then refer to figure 3-3 and remove as follows:

- (1) Disconnect cam shaft (fig. 3-1).
- (2) Remove water pressure gage (para 3-9).
- (3) Disconnect balancing water valve inlet tubing.
- (4) Remove hypochlorinator assembly mounting bolts.
- (5) Remove hypochlorinator assembly.

b. Cleaning and Inspection.

- (1) Clean the hypochlorinator with warm water and soap, and dry thoroughly.
- (2) Inspect assembly for cracks, breaks, missing parts or other damage. Report any damage to direct support maintenance personnel.

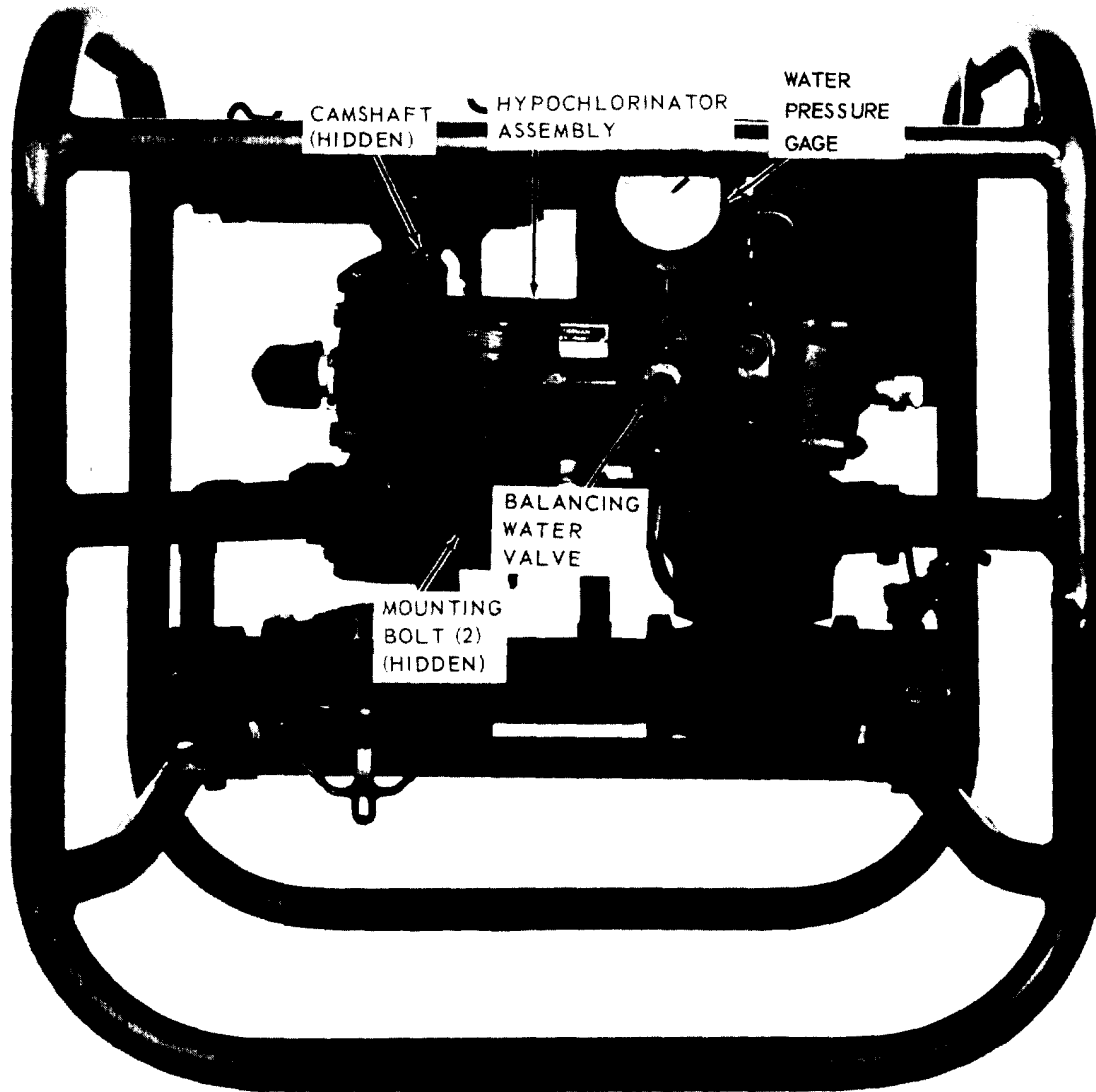

ME 4610-210-14/3-3

Figure 3-3. Hypochlorinator assembly, removal and installation.

3-13. Hypochlorinator Pumping Head Diaphragm

a. *Removal and Installation.* Refer to figure 3-4 to remove and install the hypochlorinator pumping head diaphragm.

(1) The pumping head diaphragm is located behind the pump body.

(2) When installing the pump body assembly, tighten nuts hand-tight; then secure the assembly by tightening clamping screw.

b. *Inspection.* Inspect diaphragm for breaks, cracks, or other damage. Replace if necessary,

c. *Adjustment.* If the diaphragm is removed for

any reason it must be adjusted after replacement. To adjust, refer to figure 3-5 and proceed as follows :

(1) Set length of stroke adjustment at highest mark on scale.

(2) Engage diaphragm on pump shaft, push on center of diaphragm and then pull forward to lost motion out of pump shaft assembly.

(3) Screw diaphragm on shaft to such a point that center of diaphragm has 1/8-inch clearance below a straight edge laid across flat portion of diaphragm.

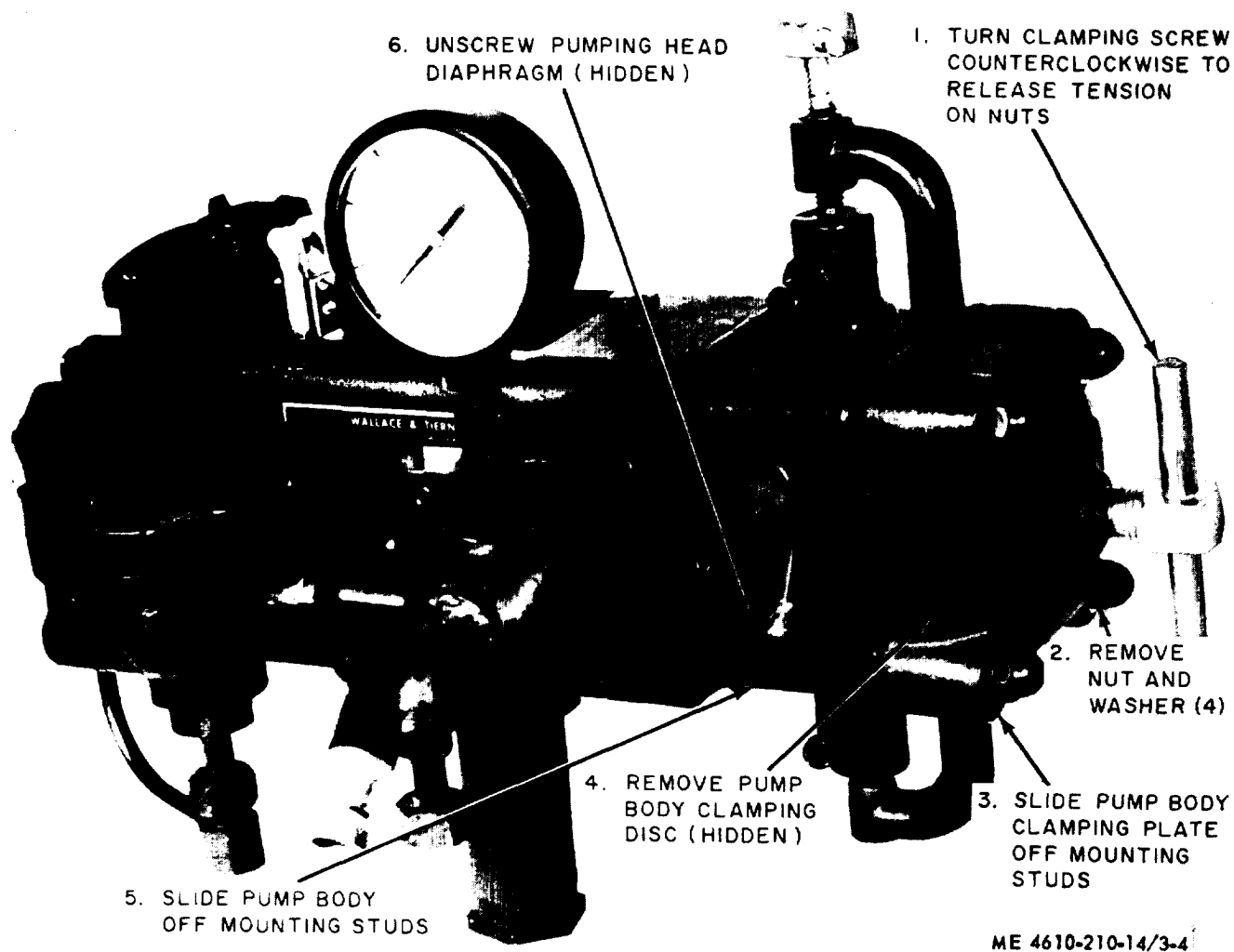
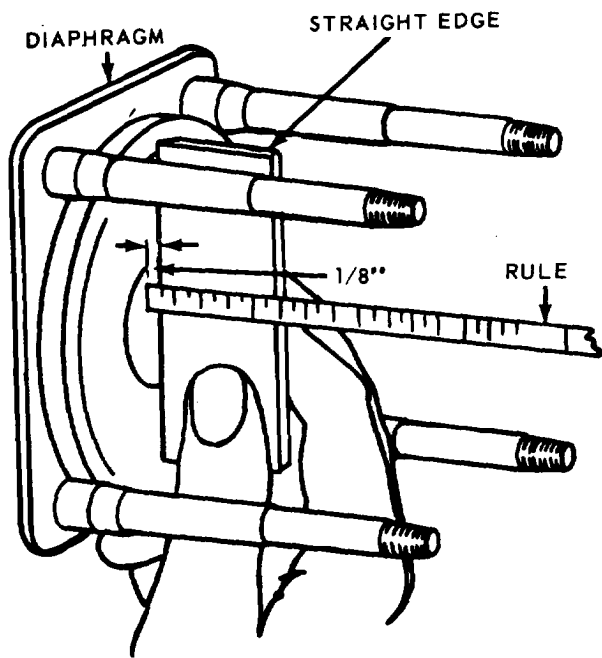

Figure 3-4. Hypochlorinator pumping head diaphragm, removal and installation.



ME 4610-210-14/3-5

Figure 3-5. Adjustment of diaphragm.

3.14. Solution Valve Body, Poppet Valve, and Valve Seat

a. *Removal and Installation.* Refer to figure 3-6 to remove and install the solution valve body, poppet valves, and valve seats.

b. *Cleaning and Inspection.*

(1) Use warm water and soap to clean body, poppet valves and valve seats. Dry thoroughly.

(2) Inspect components for breaks, cracks, or other damage. Replace any damaged component.

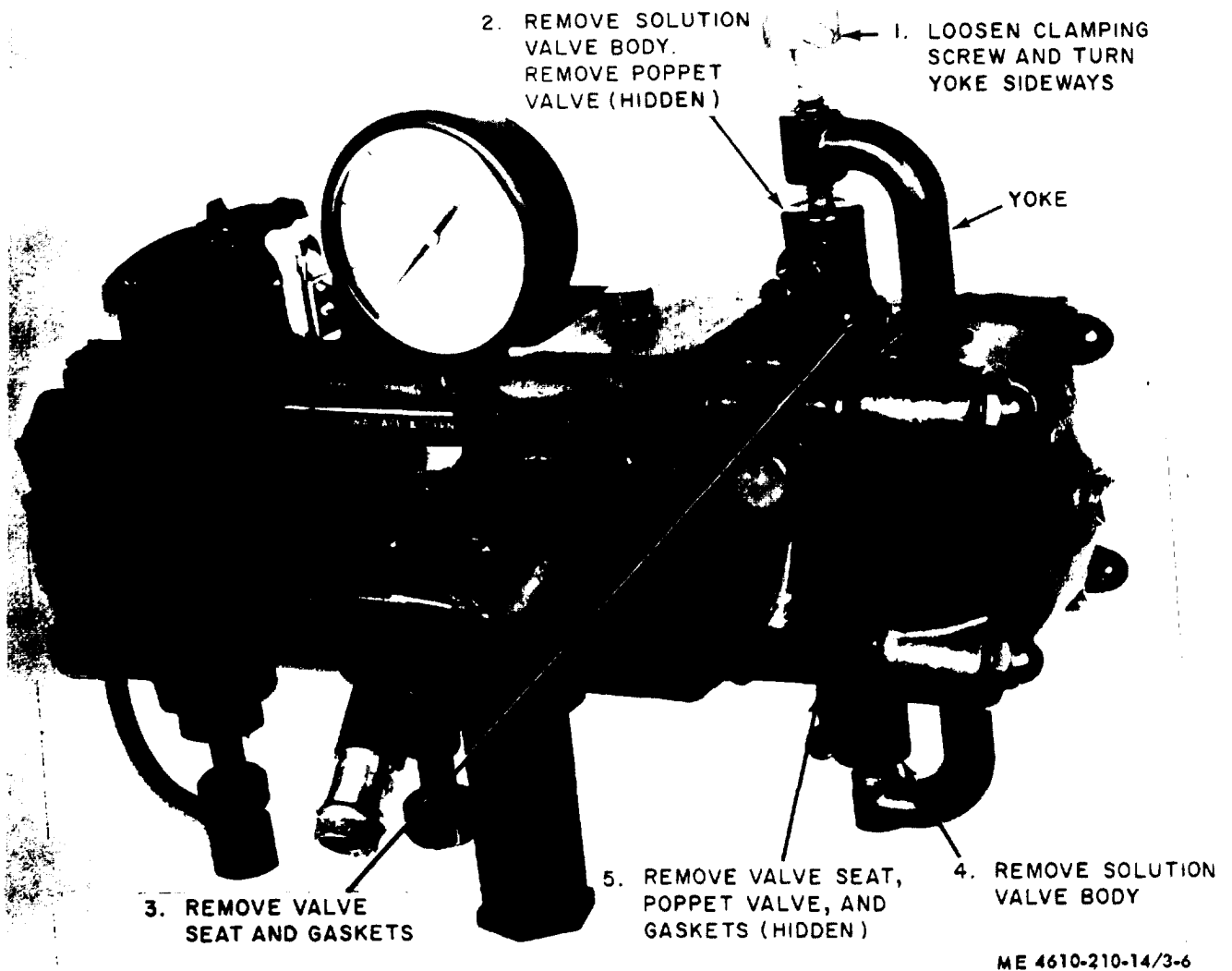

Figure 3-6. Solution valve body, poppet valves and valve seats, removal and installation.

3-15. Hypochlorite Bag.

Clean hypochlorite bag (fig. 2-1) with clear water. Check for leaks, cracks, or other damage. Repair or replace a damaged hypochlorite bag.

3-16. Range Adjusting Globe Valve and Water Pressure Regulating Valve Assemblies

a. *General.* The range adjusting and water pressure regulating valve assemblies should be removed together for simplicity.

b. *Removal and Installation.* Refer to figure 3-7 and proceed as follows:

(1) Loosen and remove two water meter coupling nuts from water meter.

(2) Disconnect and remove hypochlorinator water supply tube assembly from water supply valve.

(3) Remove hypochlorite bag inlet hose from petcock adapter (fig. 2-1).

(4) Remove hypochlorinator discharge hose from inlet fitting hose connector (fig. 2-1).

(5) Remove four mounting bolts and four washers securing main water inlet and outlet couplings to frame.

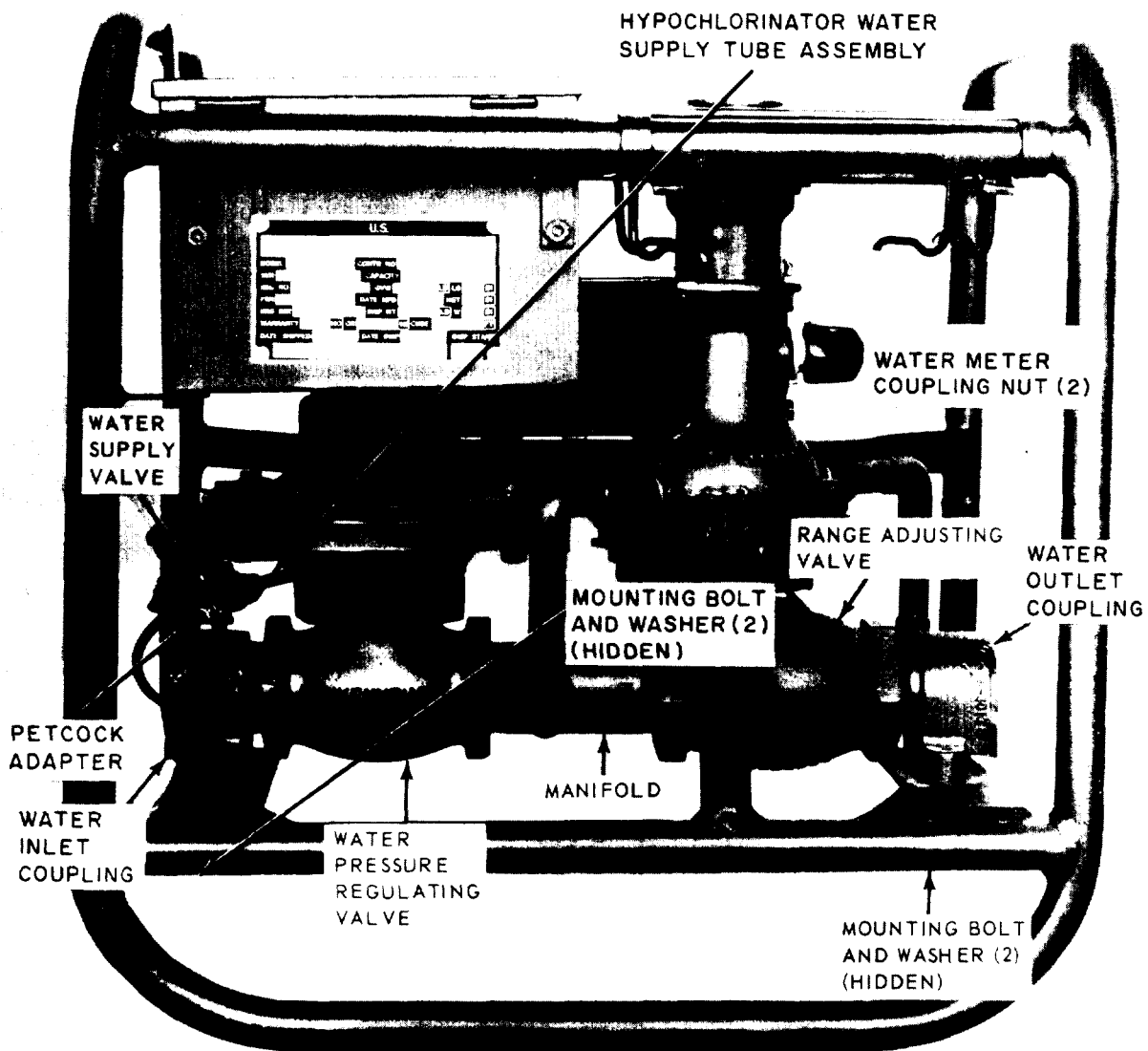

ME 4610-210-14/3-7

Figure 3-7. Range adjusting and water pressure regulating valve, removal and installation.

NOTE

To separate the water pressure regulating valve from the range adjusting valve, refer to figure 3-8.

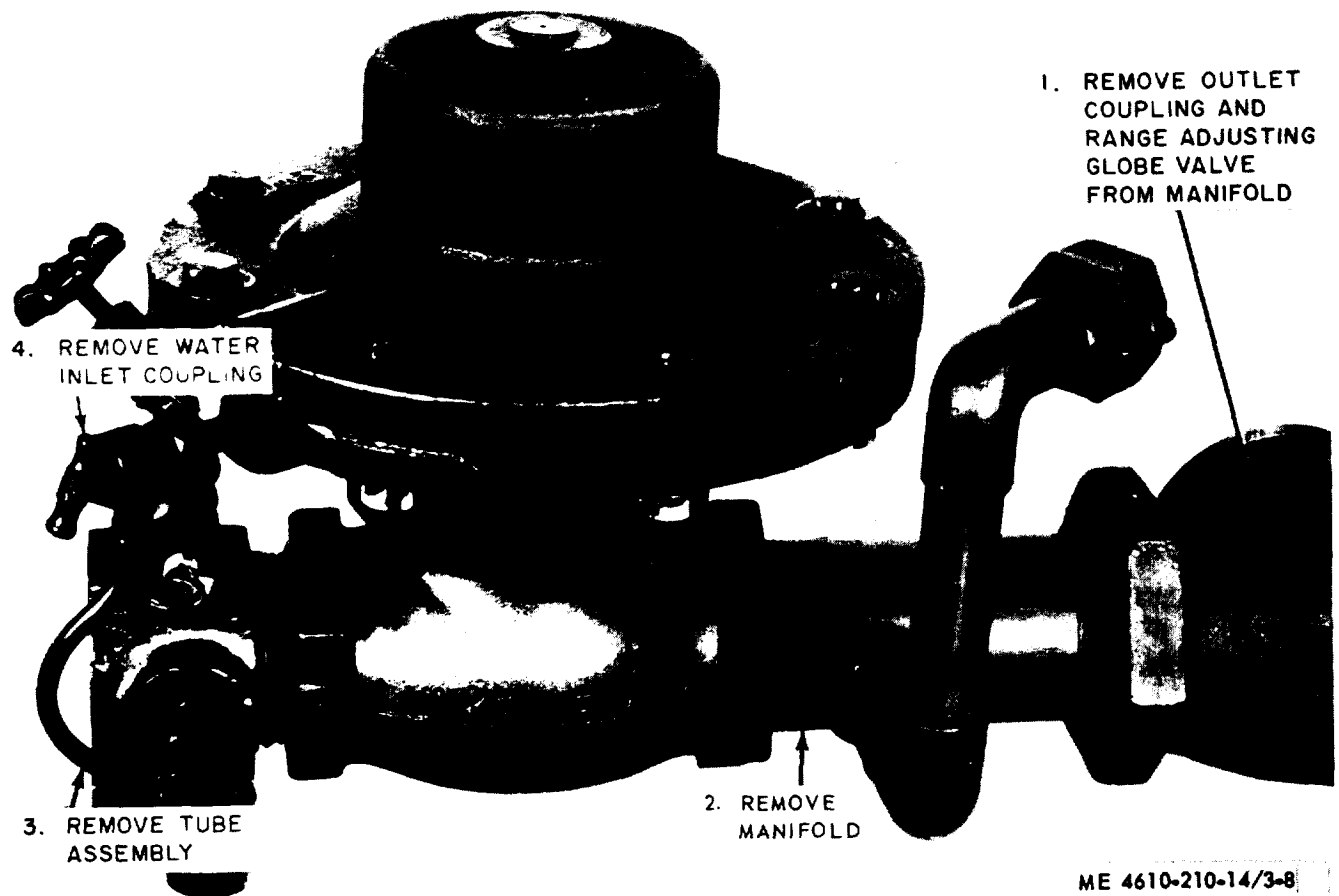

Figure 3-8. Water pressure regulating valve separation.

3-17. Flow Controller and Balancing Water Valve Assemblies

a. *Removal and Installation.* Refer to figure 3-9 to remove and install the flow controller and balancing water valve.

b. *Cleaning and Inspection.*

(1) Using warm water and soap, clean the flow

controller and balancing water valve. On the balancing water valve, remove the strainer body and clean the strainer.

(2) Inspect flow controller and balancing water valve for cracks, breaks, or other damage. Report any damage to direct support maintenance personnel.

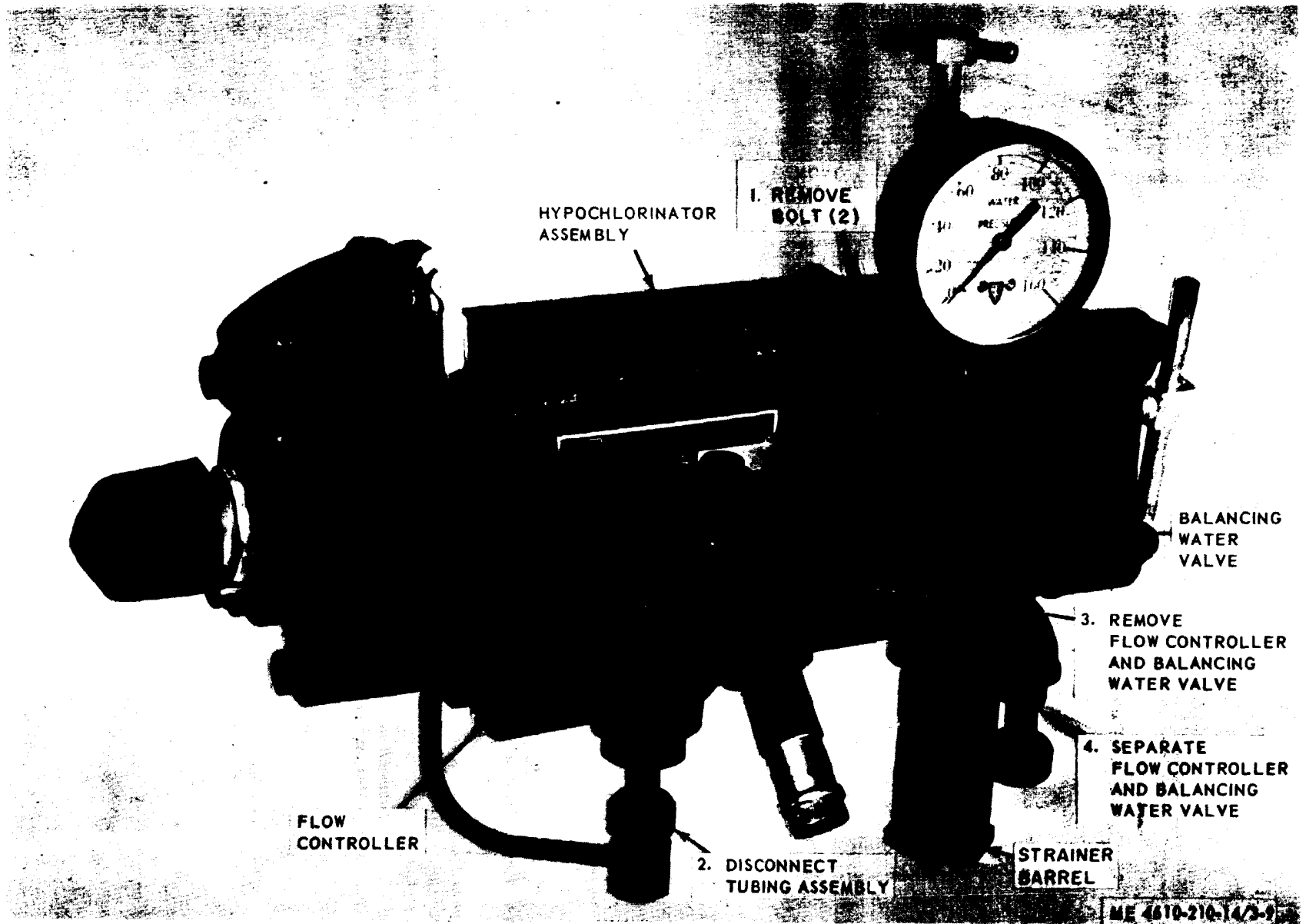

Figure 3-9. Flow controller and balancing water valve, removal and installation.

CHAPTER 4

DIRECT SUPPORT AND GENERAL SUPPORT MAINTENANCE INSTRUCTIONS

Section I. REPAIR PARTS, SPECIAL TOOLS AND EQUIPMENT

4-1. Special Tools and Equipment

No special tools or equipment are required to perform maintenance on the hypochlorination unit by direct support and general support maintenance personnel.

4-2. Maintenance Repair Parts

Direct and general support maintenance repair parts are listed in Appendix D of this manual.

Section II. TROUBLESHOOTING

4-3. General

This section provides information useful in diagnosing and correcting unsatisfactory operation or failure of the equipment and its components.

1. Each malfunction listed is followed by a list of probable causes of the trouble. The corrective action recommended is described opposite the probable cause.

4-4. Troubleshooting Procedure

Malfunctions which may occur are listed in chart 4-

Chart 4-1. Troubleshooting

Malfunction	Probable cause	Corrective Action
1. Hypochlorinator cam does not turn.	<ul style="list-style-type: none"> a. Mechanical binding in meter extension case or defective overload release. b. Meter defective. 	<ul style="list-style-type: none"> a. Rotate mechanism by hand to locate binding or wear. Replace worn or damaged part (para 5-6). b. Remove meter extension case and observe that meter shaft does not rotate with flow through meter. Repair or replace meter (para 5-6).
2. Insufficient quantity of solution delivered. Cam rotates and pump shaft moves properly.	<ul style="list-style-type: none"> a. Suction valve not seating. b. Discharge valve not seating. 	<ul style="list-style-type: none"> a. Replace valve, seat, or both (para 5-1). b. Replace valve, seat, both (para 5-1).
3. Cam turns but hypochlorinator pumping shaft does not move.	<ul style="list-style-type: none"> a. Flow controller inoperative. b. Balancing water valve is defective. c. Diaphragm valve seat the stem are defective. d. Backing springs on cam follower does not exert sufficient tension to hold diaphragm valve stem closed . e. Valve disc at open end of pump shaft is worn. 	<ul style="list-style-type: none"> a. Repair flow controller (para 5-3). b. Repair balancing water valve (para 5-4). c. Replace (para 5-2). d. Replace springs (para 5-2). e. Replace disc (para 5-2).

CHAPTER 5

REPAIR INSTRUCTIONS

Section I. HYPOCHLORINATOR ASSEMBLY

5-1. General

The hypochlorinator assembly is composed of the hypochlorinator (with pumping head), flow controller, and the balancing water valve.

5-2. Hypochlorinator

a. Removal and Installation.

(1) Refer to paragraph 3-12 to remove or install the hypochlorinator assembly.

(2) Refer to paragraph 3-17 to remove or install the flow controller and balancing water valve assemblies.

b. Disassembly. Refer to figure 5-1 and perform the following:

(1) Refer to paragraph 3-13 and remove hypochlorinator pumping head diaphragm (20).

(2) Refer to paragraph 3-14 and remove two solution valve bodies (13), poppet valves (15), two valve seats (16), and four gaskets (14) from pump body (8).

(3) Remove four studs (21), elbow (24), and nipple (25).

(4) Remove and disassemble cam bracket assembly as follows:

(a) Remove two screws (30) and washers (31) and lift off cam bracket (32).

(b) Unscrew bearing (27) from cam bracket and remove cam shaft (28) and cam (29).

(5) Remove and disassemble cam follower assembly as follows:

(a) Remove two screws (54) from drive yoke (72); then lift off cam follower assembly bracket (55).

(b) Remove two screws (62) and disassemble retainer (63) and three leaf springs (64) from support (59).

(c) Remove retainer ring (56) and push out shaft (57); then separate bracket (55), support (59), and lever (58). Remove roller shaft (60) and roller (61) from support (59).

(6) Remove and disassemble rear housing assembly as follows:

(a) Remove rear housing assembly (45) by removing four screws (43) and washers (44). Release the drive yoke.

(b) Remove nut (33) with a screwdriver and pull handle (34) straight off of shaft.

(c) Carefully remove setscrew (35) from pointer (36); spring (40) will push pointer off of shaft.

(d) Remove two screws (37); then remove dial (39), spring (40), packing gland (41), packing (42), shaft (52), and stroke adjustment nut (53).

(7) Remove and disassemble pump shaft assembly as follows:

(a) Pull the pump shaft assembly out through the rear housing end of the hypochlorinator body, (82).

(b) Unscrew guides (65 and 74) from drive yoke (72) and remove pump shaft (76).

(c) Remove washer (70), by prying if necessary; then remove valve diaphragm (71) from drive yoke (72).

(d) Push pump shaft valve seat (77) out of yoke by inserting a small punch or rod through hole in yoke behind valve seat and pressing.

(e) Remove diaphragm mounted valve seat (67) and stroke control pilot valve stem (68) by unscrewing retainer (66) from guide (65). Remove bushing (69) from guide by means of an arbor press if necessary.

(f) Remove spring retainer (79) by engaging a flat piece of bar stock in the retainer slot and unscrewing. Pull out leather packing (80), located under retainer (79) in hypochlorinator body (82).

c. Reassembly. When reassembling the hypochlorinator, refer to figure 5-1 and perform the following:

(1) Reassemble the pump shaft by reversing the procedure given in paragraph 5-2 b (7). Particular attention should be given to the following points:

(a) When pump shaft valve seat (77) is installed in yoke (72), apply a drop or two of shellac, rubber cement, or similar material to the rear face of the seat before pushing seat into yoke.

(b) When shaft guide (74) is screwed into yoke (72), be sure that pin (75) in guide fits into small hole drilled in shaft (76).

(c) Bushing (69) is a press fit in pilot valve guide (65) and should be pushed in until flush with the face of the valve guide. The fit between valve stem (68) and bushing is not critical and is satisfactory as long as the stem is sufficiently guided to seat squarely on valve seat (67).

(d) Secure valve seat (67) in valve guide (65) with retainer (66). The raised lip on valve seat (67) should face valve stem (68).

(e) Valve diaphragm (71) is clamped

between yoke (72) and washer (70) by valve guide (65). A tight joint at this point is essential.

(f) Install leather packing (80) and retainer (79) in hypochlorinator body (82). If packing (80) is hard, work a small amount of grease into it before installation. If packing is damaged use a new leather packing.

(g) Place one end of spring (73) over retainer (79) and slip pump shaft through both the spring and leather packing (80). Be careful to avoid damaging the leather packing.

(2) The correct assembly of the rear housing portion of the hypochlorinator is important since the proper pumping stroke length can be obtained only if the correct relationship exists among the parts involved in this assembly. When assembling perform the following:

(a) Screw stroke adjustment nut (53) on shaft (52) as far as it will go. Slip shaft through hole in center of housing (45) and be sure that guide pin (51) passed through hole in adjustment nut (53).

(b) Place housing (45), shaft (52), and adjustment nut (53) on a flat block so that the block supports the adjusting nut but clears the edges of the housing. Install dial (39), asbestos cord packing (42) dipped in water-proof grease, packing gland (41), and spring (40). Place pointer (36) in position so that spring (40) fits inside dial (39). Push down on the pointer until setscrew (35) lines up with the groove in shaft (52); then tighten setscrew. An arbor press can be used for this operation by using a piece of tubing, roughly $\frac{3}{4}$ inch OD x $\frac{1}{2}$ inch ID to exert pressure on the pointer.

(c) Turn pointer (36) clockwise until shaft (52) locks in adjustment nut (53). The pointer should be at 10 on the dial. If this is not the case, loosen setscrew (35) slightly, hold the shaft, and adjust pointer position on shaft until proper adjustment is obtained. After correct position is achieved, tighten setscrew securely.

(d) Install handle (34) and secure with locknut (33).

(3) Assemble and install the cam follower assembly by reversing the steps given in paragraph 5-2 b (5). Make sure three leaf springs (64) are installed so that lower end of springs tend to push lever (58) towards valve diaphragm (71).

(4) Assemble and install cam bracket assembly as follows:

(a) Slip cam shaft (28) through bearing (27). Assemble cam (29), bearing, and shaft in

bracket (32). Make sure the square shank of cam shaft fits into square in center of cam. Tighten bearing securely.

(b) See that cam lobes curve in direction shown in figure 5-1. If the cam is reversed, it will lock on the cam roller and the hypochlorinator will not operate. After assembly the cam shaft should rotate freely with no trace of friction or binding.

(c) Assemble cam bracket (32) to hypochlorinator body (82) with two screws (30) and washers (31).

(5) Install four studs (21), elbow (24), and nipple (25) in hypochlorinator body (82).

(6) Assemble and install pumping head assembly as follows:

(a) Refer to paragraph 3-14 and install valve seats (16), poppet valves (15), gaskets (14), and solution valve bodies (13) in pump body (8).

(b) Refer to paragraph 3-13, and install and adjust the pumping head diaphragm in hypochlorinator assembly.

(7) Install hypochlorinator assembly in automatic hypochlorinator unit as follows:

(a) Refer to paragraph 3-17 and install flow controller and balancing water valve assemblies.

(b) Refer to paragraph 3-12 and install hypochlorinator assembly.

(c) Check length of stroke as follows:

1. When stroke control pointer (36) is set at 10 on dial (39), driving yoke (72) should travel $5 / 16$ on the power (forward) stroke. The unit is designed so that a $5 / 16$ -inch yoke movement produces a $1/4$ -inch movement of pump shaft (76). The yoke travel is influenced by the position of the cam roller with respect to the cam.

2. Place the hypochlorinator assembly in operation and measure the length of driving yoke movement with the stroke adjusting pointer set at 10 on the dial. The movement of the yoke can be easily and accurately measured by clamping a piece of wire under one of the screws (54) which secures the roller support bracket (55) to the driving yoke, and bringing the free end of the wire outside of the hypochlorinator body to serve as a pointer.

3. If the distance measured is more than $5 / 16$ inch, loosen the two screws (30) and move cam bracket (32) back (away) from cam roller (61) a small amount. If the movement is less than $5 / 16$ inch, move bracket forward. When correct yoke travel length of $5 / 16$ inch is obtained, remove wire pointer (if used), and tighten screws (30 and 54) securely.

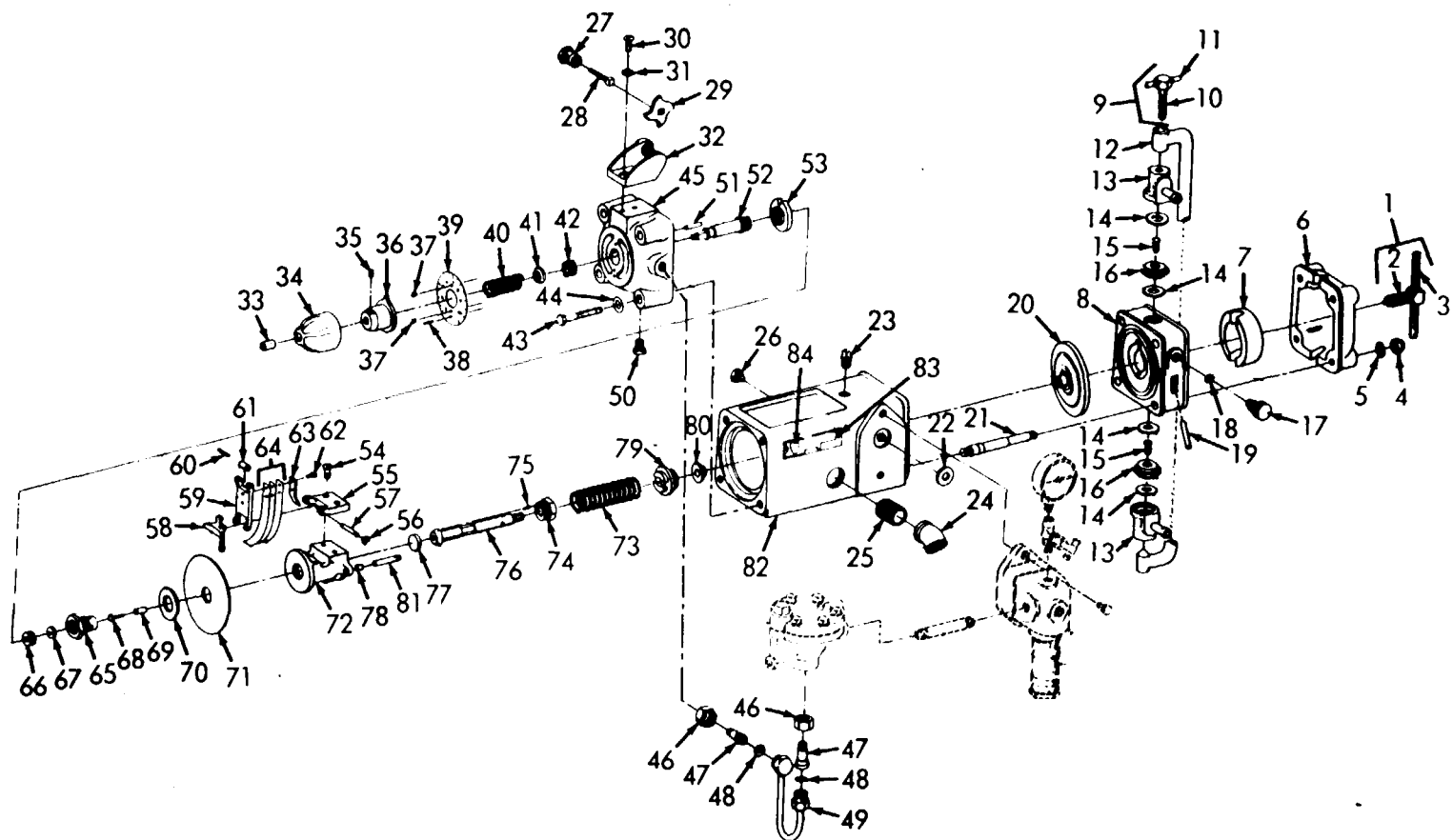

ME 4610-210-14/5-1

Figure 5-1. Hypochlorinator disassembly and reassembly.

Key to figure 5-1.

1 Clamp assembly	29 Cam	57 Shaft
2 Screw	30 Screw	58 Lever
3 Pin	31 Washer	59 Support
4 Nut (4)	32 Bracket	60 Roller shaft
5 Washer (4)	33 Locknut	61 Roller
6 Plate	34 Handle	62 Screw
7 Clamping disk	35 Setscrew	63 Retainer
8 Body	36 Pointer	64 Leaf spring (3)
9 Yoke clamp assembly	37 Screw (2)	65 Guide
10 Screw	38 Pin	66 Retainer
11 Pin	39 Dial	67 Valve seat
12 Yoke	40 Spring	68 Stroke valve stem
13 Body	41 Packing gland	69 Bushing
14 Gasket (4)	42 Packing	70 Washer
15 Poppet valves (2)	43 Bolt	71 Diaphragm
16 Valve seats (2)	44 Washer (4)	72 Drive yoke
17 Priming plug	45 Housing	73 Spring
18 Priming plug gasket	46 Union nut (2)	74 Guide
19 Tube	47 Union nipple (2)	75 Pin
20 Diaphragm	48 Gasket (2)	76 Pump shaft
21 Stud	49 Water inlet tube	77 Seat
22 Gasket	50 Pipe plug	78 Bearing
23 Pipe plug	51 Guide pin	79 Retainer
24 Elbow	52 Shaft	80 Packing
25 Nipple	53 Stroke adjustment nut	81 Guide pin (2)
26 Pipe plug	54 Screw (2)	82 Body
27 Bearing	55 Bracket	83 Drive screw (2)
28 Cam shaft	56 Retaining ring	84 Nameplate

5-3. Flow Controller

a. Removal and Installation. Refer to paragraph 3-17 to remove and install the flow controller.

b. Disassembly and Reassembly. Refer to figure 5-2 to disassemble and reassemble the flow controller.

c. Cleaning, Inspection, and Repair.

(1) Clean all parts with warm water and soap and dry thoroughly.

(2) Inspect for cracks, breaks, or other damage. Replace any defective parts.

5-4. Balancing Water Valve

a. Removal and Installation. Refer to paragraph

3-17 to remove and install the balancing water valve.

b. Disassembly and Reassembly. Refer to figure 5-3 to disassemble and reassemble the balancing water valve.

c. Cleaning, Inspection, and Repair.

(1) Clean all parts with warm water and soap and dry thoroughly.

(2) Inspect for cracks, breaks, or other damage. Replace any defective part.

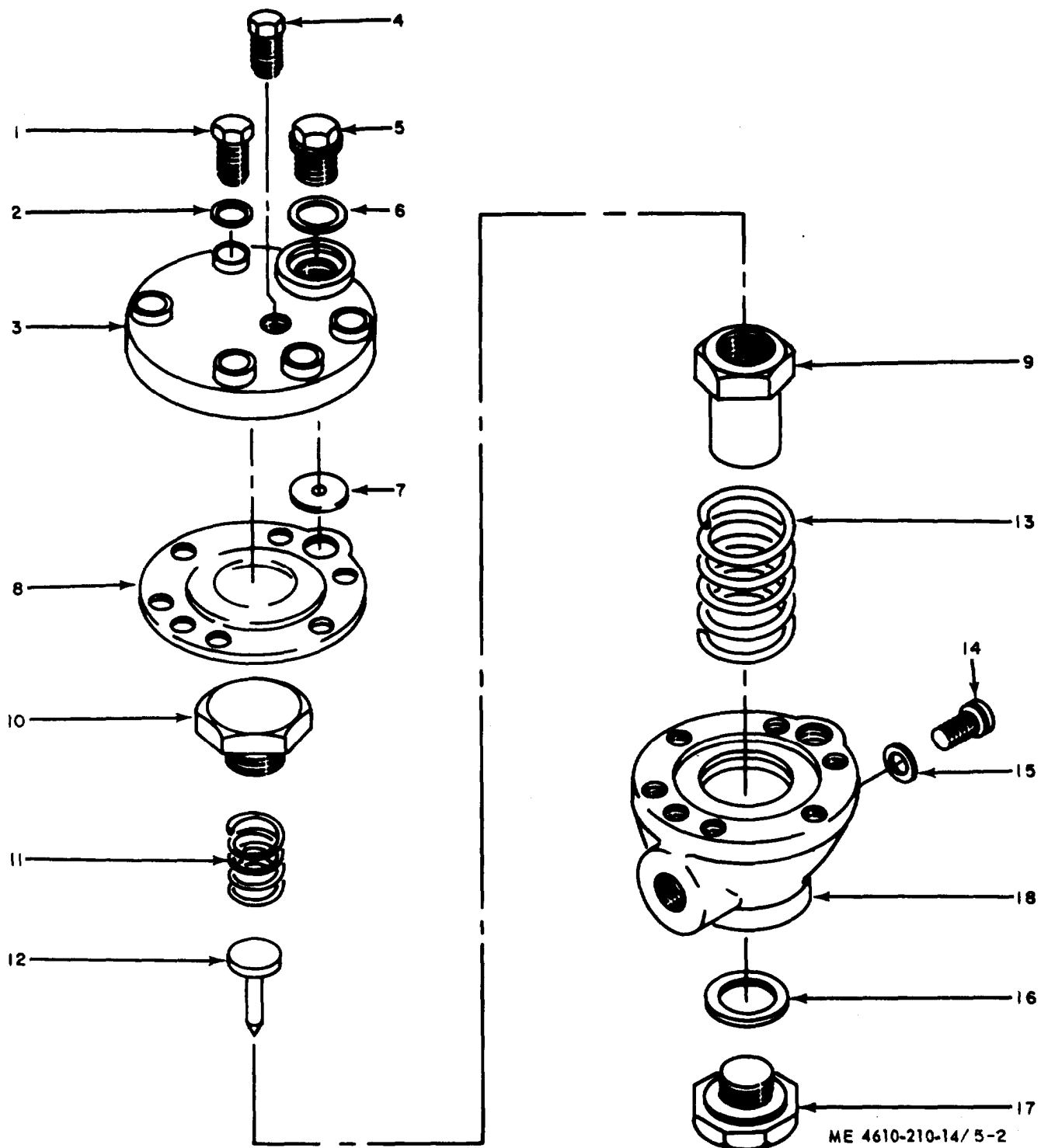

- 1 Bolt (6)
- 2 Washer (6)
- 3 Cap
- 4 Pipe plug
- 5 Plug
- 6 Lead gasket
- 7 Valve seat
- 8 Diaphragm
- 9 Spring retainer

- 10 Backing plate
- 11 Spring
- 12 Valve pin
- 13 Spring
- 14 Screw
- 15 Gasket
- 16 Gasket
- 17 Adapter
- 18 Valve body

ME 4610-210-14/5-2

Figure 5-2. Flow controller, disassembly and reassembly.

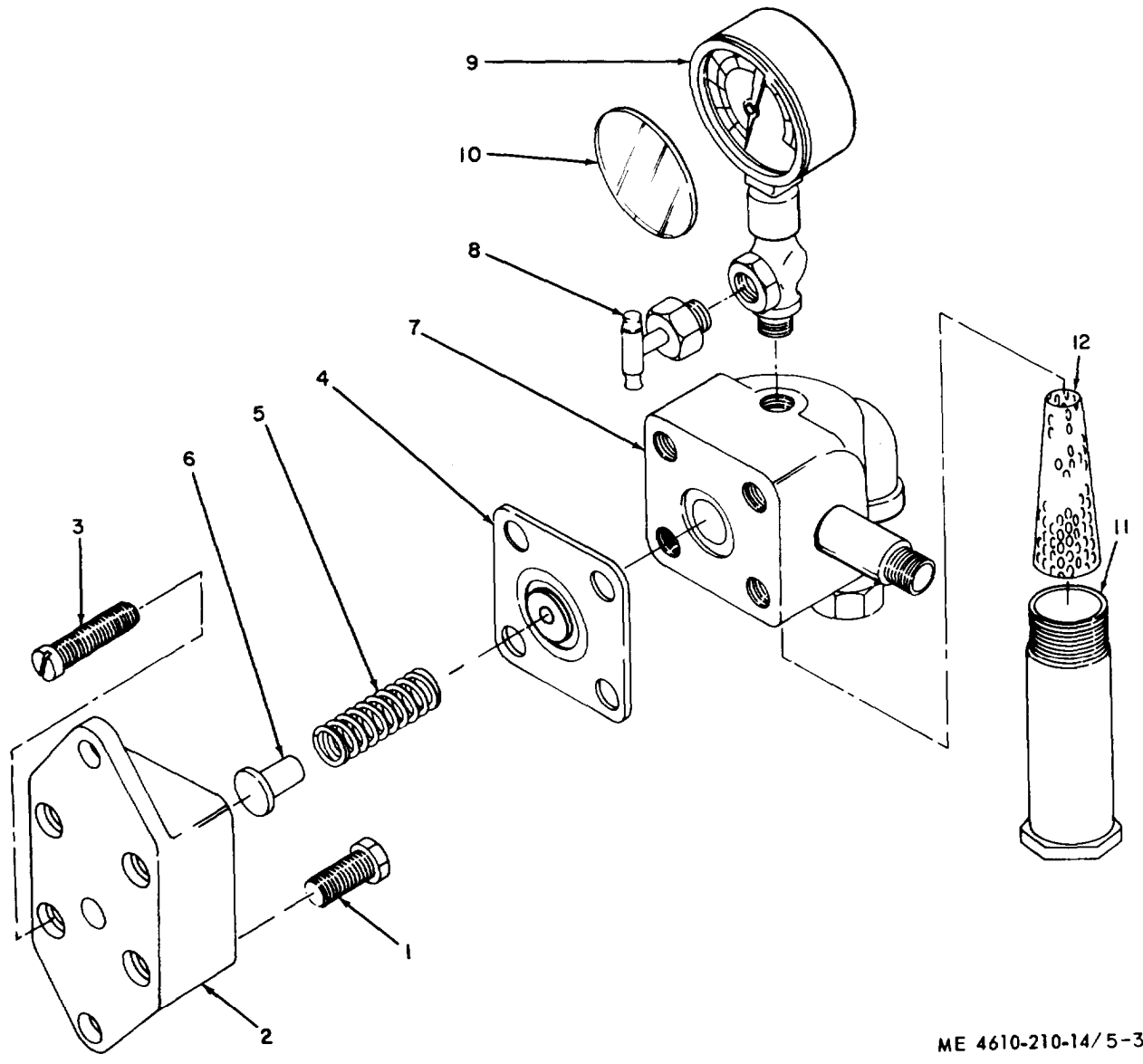

ME 4610-210-14/5-3

- 1 Bolt (2)
- 2 Body
- 3 Bolt (4)
- 4 Diaphragm assembly
- 5 Spring
- 6 Stem

- 7 Head
- 8 Petcock
- 9 Gage
- 10 Lens
- 11 Barrel
- 12 Screen

Figure 5-3. Balancing water valve, disassembly and reassembly.

Section II. WATER CONTROL AND MEASUREMENT

5-5. Range Adjusting Valve Assembly

a. Removal and Installation. Refer to paragraph 3- 16 to remove and install the range adjusting valve assembly.

b. Disassembly and Reassembly. Refer to figure 5-4 to disassemble and reassemble the range adjusting valve assembly.

c. Cleaning, Inspection, and Repair.

(1) Clean all parts with warm water and soap, and dry thoroughly.

(2) Inspect for cracks, breaks, or other damage. Replace any defective part.

5-6. Water Meter Assembly

The water meter assembly consists of the register box, register, and the housing assembly. Refer to paragraph 3-12 to remove and install the water meter assembly. Refer to figure 5-5 to disassemble and reassemble the water meter assembly.

Key to figure 5-4.

1 Nut	8 Bonnet
2 Washer	9 Nut
3 Handle	10 Stem
4 Nut	11 Washer
5 Gland	12 Plug
6 Packing	13 Seat
7 Ring	14 Body

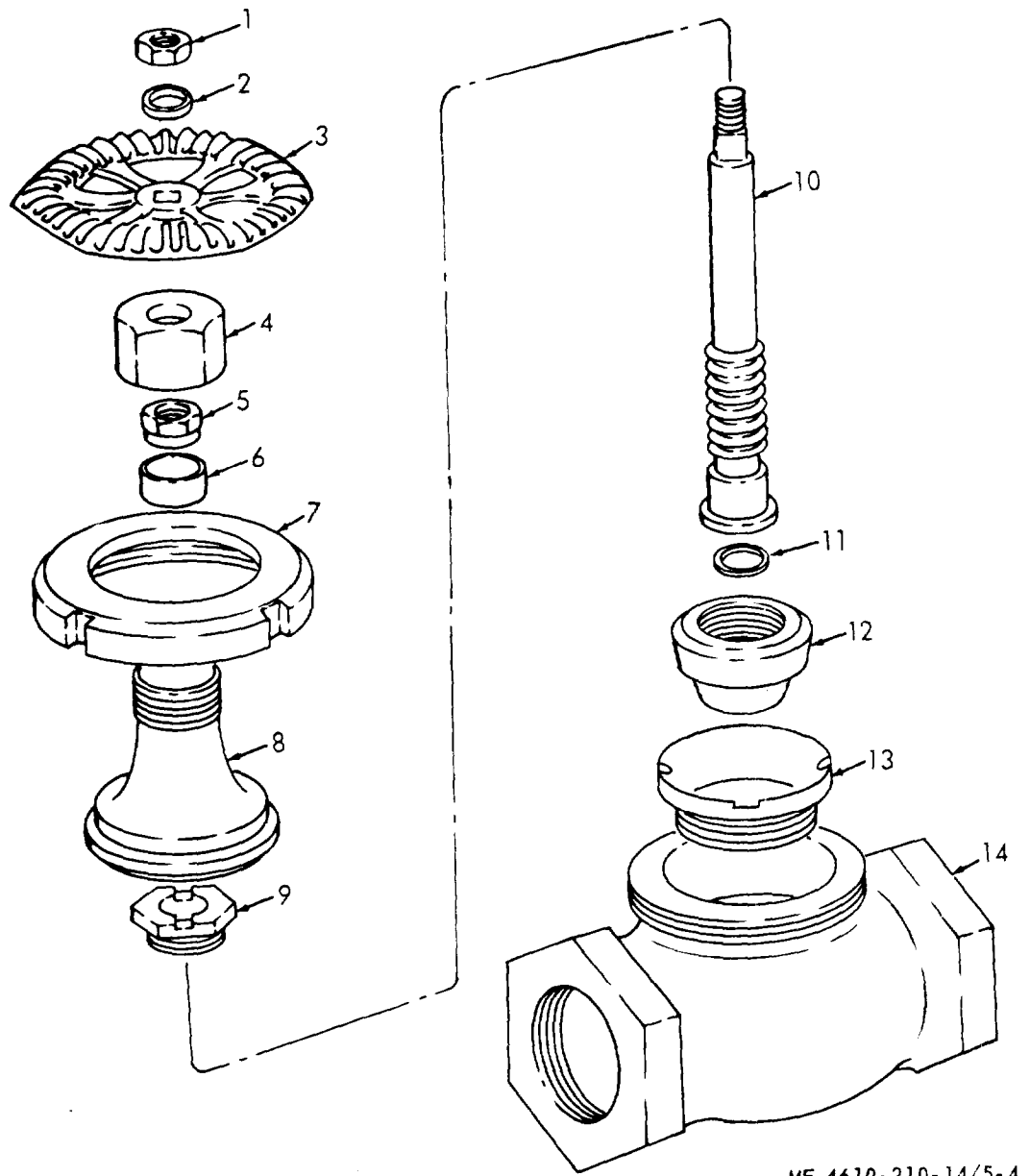

ME 4610-210-14/5-4

Figure 5-4. Range adjusting valve, disassembly and reassembly.

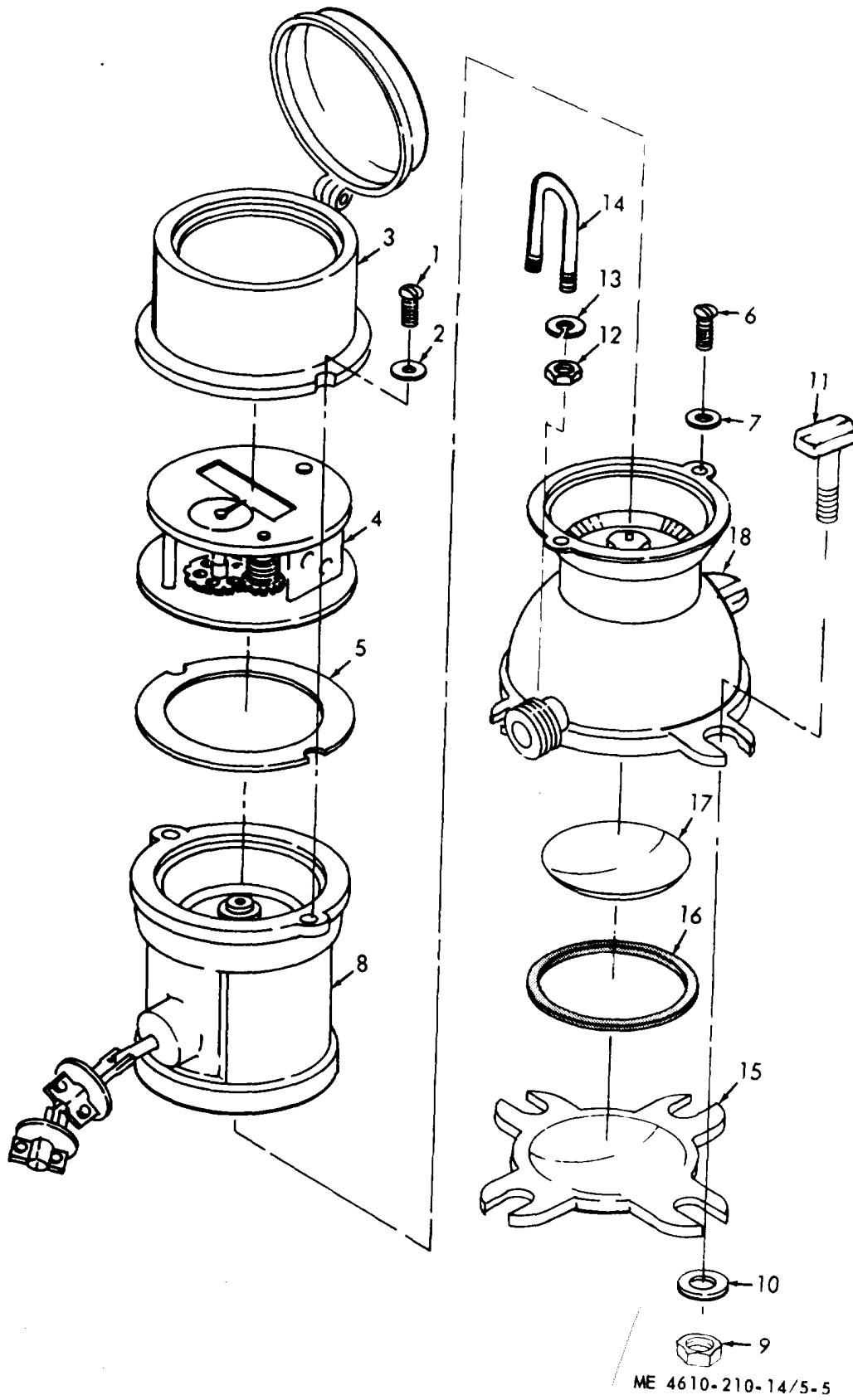

Figure 5-5. Water meter assembly, disassembly and reassembly.

Key to figure 5-5.

- | | |
|----------------|------------|
| 1 Screw | 10 Washer |
| 2 Washer | 11 Bolt |
| 3 Register box | 12 Nut |
| 4 Gear train | 13 Washer |
| 5 Gasket | 14 U-bolt |
| 6 Screw | 15 Cap |
| 7 Washer | 16 Gasket |
| 8 Casing | 17 Lining |
| 9 Nut | 18 Housing |

5-7. Water Pressure Regulating Valve

a. *Removal and installation.* Refer to paragraph 3-16 to remove and install the water pressure regulating valve.

b. *Disassembly and Reassembly.* Refer to figure 5-6 to disassemble and reassemble the water pressure regulating valve.

WARNING

Before disassembling the diaphragm housing assembly (items 5 and 12 of figure 5-6), place a clamp across the housing. Failure to do so may result in injury due to the release of pressure on the spring outside of the housing.

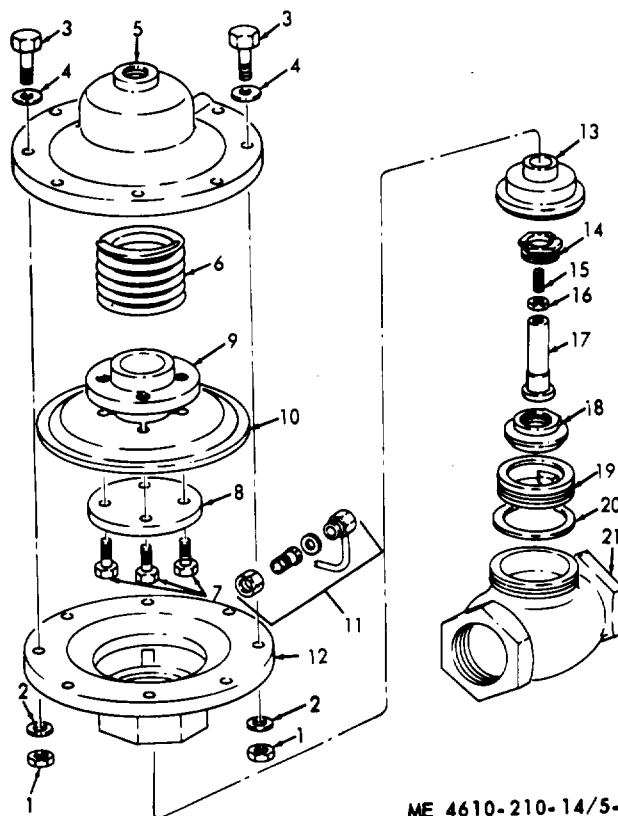

- | | |
|------------------|-----------|
| 1 Nut | 12 Flange |
| 2 Washer | 13 Guide |
| 3 Bolt | 14 Nut |
| 4 Washer | 15 Bolt |
| 5 Flange | 16 Nut |
| 6 Spring | 17 Stem |
| 7 Screw | 18 Disk |
| 8 Lockplate | 19 Ring |
| 9 Retainer | 20 Shim |
| 10 Diaphragm | 21 Body |
| 11 Line assembly | |

Figure 5-6. Water pressure regulating valve, disassembly and reassembly.

APPENDIX A REFERENCES

A-1. Painting

TM 9-213

Painting Instructions for Field Use

A-2. Maintenance

TM 38-750

Army Maintenance Management System

A-3. Shipment and Storage

TM 740-90-1

Administrative Storage of Equipment

A-4. Demolition

TM 750-244-3

Destruction of Materiel to Prevent Enemy Use

APPENDIX B

MAINTENANCE ALLOCATION CHART

Section I. INTRODUCTION

B-1. General

a. This section provides a general explanation of all maintenance and repair functions authorized at various maintenance levels.

b. Section II designates overall responsibility for the performance of maintenance functions on the identified end item or component. The implementation of the maintenance functions upon the end item or component will be consistent with the assigned maintenance functions.

c. Section III not applicable.

d. Section IV not applicable.

B-2. Explanation of Columns in Section II

a. *Group Number, Column (1).* The assembly group is a numerical group assigned to each assembly in a top-down breakdown sequence. The applicable assembly groups are listed on the MAC (Maintenance Allocation Chart) in disassembly sequence beginning with the first assembly removed in a top-down disassembly sequence.

b. *Assembly Group, Column (2).* This column contains a brief description of the components of each assembly group.

c. *Maintenance Functions, Column (3).* This column lists the various maintenance functions (A through K) and indicates the lowest maintenance category authorized to perform these functions. The symbol designations for the various maintenance categories are as follows:

C—Operator or crew
O—Organizational maintenance
F—Direct support maintenance
H—General support maintenance

The maintenance functions are defined as follows:

A—Inspect: To determine serviceability of an item by comparing its physical, mechanical, and electrical characteristics with established standards.

B—Test: To verify serviceability and to detect electrical or mechanical failure by use of test equipment.

C—Service: To clean, to preserve, to charge, to paint, and to add fuel, lubricants, cooling agents, and air.

D—Adjust: To rectify to the extent necessary to bring into proper operating range.

E—Align: To adjust specified variable elements of an item to bring to optimum performance.

F—Calibrate: To determine the corrections to be made in the readings of instruments or test equipment used in precise measurement. Consists of the comparisons of two instruments, one of which is a certified standard of known accuracy, to detect and adjust any discrepancy in the accuracy of the instrument being compared with the certified standard.

G—Install: To set up for use in an operational environment such as an emplacement, site, or vehicle.

H—Replace: To replace unserviceable items with serviceable assemblies, subassemblies, or parts.

I—Repair: To restore an item to serviceable condition. This includes, but is not limited to, inspection, cleaning, preserving, adjusting, replacing, welding, riveting, and strengthening.

J—Overhaul: To restore an item to a completely serviceable condition as prescribed by maintenance serviceability standards using the Inspect and Repair Only as Necessary (IROAN) technique.

K—Rebuild: To restore an item to a standard as nearly as possible to original or new condition in appearance, performance, and life expectancy. This is accomplished through complete disassembly of the item, inspection of all parts or components, repair or replacement of worn or unserviceable elements (items), using original manufacturing tolerances and specifications, and subsequent reassembly of the item.

d. *Tools and Equipment, Column (4).* This column is provided for referencing by code the special tools and test equipment (sec. III) required to perform the maintenance functions (sec II).

e. *Remarks, Column (5).* This column is provided for referencing by code the remarks (sec. IV) pertinent to the maintenance functions.

Section II. MAINTENANCE ALLOCATION CHART

(1) Group No.	(2) Assembly group	(3) Maintenance functions											(4) Tools and equipment	(5) Remarks		
		A	B	C	D	E	F	G	H	I	J	K				
		Inspect	Test	Service	Adjust	Align	Calibrate	Install	Replace	Repair	Overhaul	Rebuild				
01	WATER METERS															
	Water meter	O							O	F	H					
	Chamber	O							O	F						
	Register box								O	O						
	Case assembly	O							F							
02	WATER PURIFICATION															
	Hypochlorinator assembly			O					O	F	H					
	Pumping head diaphragm	O			O				O							
	Flow controller			O					O	F						
	Balancing water valve			O					O	F						
	Range adjusting valve assy								O	F						
	Pressure regulating valve								O	F						
03	MISCELLANEOUS															
	Hypochlorite bag	C			O					O						

APPENDIX C

BASIC ISSUE ITEMS LIST

Section I. INTRODUCTION

C-1. Scope

This appendix lists items which accompany the hypochlorination unit or are required for installation, operation, or operator's maintenance.

C-2. General

This basic issue items list is divided into the following sections:

a. Basic Issue Items—Section II. A list of items which accompany the hypochlorination unit and are required by the operator / crew for installation, operation, or maintenance.

b. Maintenance and Operating Supplies—Section III. (Not applicable.)

C-3. Explanation of Columns

The following provides an explanation of columns in the tabular list of basic issue items, section II.

a. Source, Maintenance, and Recoverability Codes (SMR).

(1) Source code indicates the selection status and source for the listed item. Source codes are:

<i>Code</i>	<i>Explanation</i>
P	Repair parts which are stocked in or supplied from the GSA / DSA or Army supply system, and authorized for use at indicated maintenance categories.
M	Repair parts which are not procured or stocked, but are to be manufactured at indicated maintenance levels.
A	Assemblies which are not procured or stocked as such, but are made up of two or more units. Such component units carry individual stock numbers and descriptions, are procured and stocked separately and can be assembled to form the required assembly at indicated maintenance categories.
X	Parts and assemblies which are not procured or stocked and the mortality of which normally is below that of the applicable end item or component. The failure of such part or assembly should result in retirement of the end item from the supply system.
X1	Repair parts which are not procured or stocked. The requirements of such items will be filled by use of the next higher assembly or component.
X2	Repair parts, which are not stocked. The indicated maintenance category requiring such repair parts will attempt to obtain them through cannibalization. Where such repair parts are not obtainable through cannibalization, requirements will be requisitioned, with accompanying justification, through normal supply channels.
G	Major assemblies that are procured with PEMA funds for initial issue only as exchange

assemblies at DSU and GSU level. These assemblies will not be stocked above GS and DS level or returned to depot supply levels.

(2) Maintenance code indicates the lowest category of maintenance authorized to install the listed items. The maintenance level code is:

<i>Code</i>	<i>Explanation</i>
C	Operator / crew

(3) Recoverability code indicates whether unserviceable items should be returned for recovery or salvage. Items not coded are expendable. Recoverability codes are:

<i>Code</i>	<i>Explanation</i>
R	Applied to repair parts (assemblies and components) which are considered economically repairable at direct and general support maintenance levels. When the maintenance capability to repair these items does not exist, they are normally disposed of at the GS level. When supply considerations dictate, some of these repair parts may be listed for automatic return to supply for depot level repair as set forth in AR 710-50. When so listed, they will be replaced by supply on an exchange basis.
S	Repair parts and assemblies which are economically repairable at DSU and GSU activities and which normally are furnished by supply on an exchange basis. When items are determined by a GSU to be uneconomically repairable they will be evacuated to a depot for evaluation and analysis before final disposition.
T	High dollar value recoverable repair parts which are subject to special handling and are issued on an exchange basis. Such repair parts are normally repaired or overhauled at depot maintenance activities.
u	Repair parts specifically selected for salvage by reclamation units because of precious metal content, critical materials, or high dollar value reusable casings or castings.

b. Federal Stock Number. This column indicates the Federal stock number assigned to the item and will be used for requisitioning purposes.

c. Description. This column indicates the Federal item name and any additional description of the item required.

d. Unit of Measure (U / M). A two-character alphabetic abbreviation indicating the amount or quantity of the item upon which the allowances are based: e.g., ft, ea, pr, etc.

e. Quantity Incorporated in Unit. (Not applicable.)

f. Quantity Furnished With Equipment. This

column indicates the quantity of an item furnished with the equipment.

g. Illustration. (Not applicable.)

Section II. BASIC ISSUE ITEMS

(1) SMR code	(2) Federal stock number	(3) Description		(4) Unit of meas	(5) Qty inc in unit	(6) Qty furn with equip	(7) Illustration	
		Ref No. & Mfr Code	Usable on code				(A) Fig No.	(B) Item No.
PC	7510-889-3494	BINDER, Looseleaf		EA		1		
PC	7520-559-9618	CASE, Operator and Maintenance Publications		EA		1		
		ARMY TECHNICAL MANUAL TM 5-4610-210-14		EA		1		

APPENDIX D

REPAIR PARTS AND SPECIAL TOOLS LIST

Section I. INTRODUCTION

D-1. Scope

This appendix lists repair parts required for the performance of organizational, direct support, and general support maintenance of the water purification unit.

D-2. General

This repair parts list is divided into the following sections:

a. Prescribed Load Allowance (PLA)—Section II. A composite listing of repair parts having quantitative allowances for initial stockage at the organizational level.

b. Repair Parts—Section III. A list of repair parts authorized for the performance of maintenance at the organizational level in figure and item number sequence.

c. Special Tools, Test and Support Equipment—Section IV. (Not applicable.)

d. Repair Parts—Section V. A list of repair parts authorized for the performance of maintenance at the direct and general support level in figure and item number sequence.

e. Special Tools, Test and Support Equipment—Section VI. (Not applicable.)

f. Federal Stock Number and Reference Number Index—Section VII. A list of Federal stock numbers in ascending numerical sequence, followed by a list of reference numbers appearing in all the listing, in ascending alphanumeric sequence, cross-referenced to the illustration figure number and item number.

D-3. Explanation of Columns

The following provides an explanation of columns in the tabular lists in sections II through VII.

a. Source, Maintenance, and Recoverability Codes (SMR).

(1) *Source code.* Indicates selection status and source for listed item. Source codes are:

<i>Code</i>	<i>Explanation</i>
P	Repair parts which are stocked in or supplied from the GSA / DSA or Army supply system, and authorized for use at indicated maintenance categories.
M	Repair parts which are not procured or stocked, but are to be manufactured at indicated maintenance levels.
A	Assemblies which are not procured or stocked as such, but are made up of two or more units. Such component units carry individual stock numbers and descriptions, are procured and

<i>Code</i>	<i>Explanation</i>
	stocked separately and can be assembled to form the required assembly at indicated maintenance categories
X	Parts and assemblies which are not procured or stocked and the mortality of which normally is below that of the applicable end item or component. The failure of such part or assembly should result in retirement of the end item from the supply system.
X1	Repair parts which are not procured or stocked. The requirement of such items will be filled by use of the next higher assembly or component.
X2	Repair parts which are not stocked. The indicated maintenance category requiring such repair parts will attempt to obtain them through cannibalization. Where such repair parts are not obtainable through cannibalization, requirements will be requisitioned, with accompanying justification, through normal supply channels.
G	Major assemblies that are procured with PEMA funds for initial issue only as exchange assemblies at DSU and GSU level. These assemblies will not be stocked above GS and DS level or returned to depot supply level.

(2) *Maintenance code.* Indicates the lowest category of maintenance authorized to install the listed item. The maintenance codes are:

<i>Code</i>	<i>Explanation</i>
O.	Organizational maintenance
F.	Direct support maintenance
H.	General support maintenance

(3) *Recoverability code.* Indicates whether unserviceable items should be returned for recovery or salvage, Items not coded are expendable. Recoverability codes are:

<i>Code</i>	<i>Explanation</i>
R	Applied to repair parts (assemblies and components) which are considered economically repairable at direct and general support maintenance levels. When the maintenance capability to repair these items does not exist, they are normally disposed of at the GS level. When supply considerations dictate, some of these repair parts may be listed for automatic return to supply for depot level repair as set forth in AR 710-50. When so listed, they will be replaced by supply on an exchange basis.
S	Repair parts and assemblies which are economically repairable at DSU and GSU activities and which normally are furnished by supply on an exchange basis. When items are determined by a GSU to be uneconomically

<i>Code</i>	<i>Explanation</i>
	repairable they will be evacuated to a depot for evaluation and analysis before final disposition.
T	High dollar value recoverable repair parts which are subject to special handling and are issued on an exchange basis. Such repair parts are normally repaired or overhauled at depot maintenance activities.
U	Repair parts specifically selected for salvage by reclamation units because of precious metal content, critical materials, or high dollar value reusable casings or castings.

b. Federal Stock Number. Indicates the Federal stock number assigned to the item and will be used for requisitioning purposes.

c. Description. Indicates the Federal item name and any additional description of the item required. Assembly components and subassemblies are indented under major assemblies. A part number or other reference number is followed by the applicable 5-digit Federal supply code for manufacturers, in parentheses. Material required for manufacture or fabrication is identified.

d. Unit of Measure (U/M). A two-character alphabetic abbreviation indicating the amount or quantity of the item upon which the allowances are based; e.g., ft, ea, pr, etc.

e. Quantity Incorporated in Unit. Indicates the quantity of the item used in the assembly group.

f. Fifteen-Day Organizational Maintenance Allowance.

(1) The allowance columns are divided into four subcolumns. Indicated in each subcolumn opposite the first appearance of each item is the total quantity of the items authorized for the number of equipments supported. Subsequent appearances of the same item will have the letters "REF" in the allowance column. To locate the referenced item, locate the FSN or reference number in the index. The earliest figure and item number is the referenced item. Items authorized for use as required but not for initial stockage are identified with an asterisk in the allowance column.

(2) The quantitative allowance for organizational level of maintenance represents one initial prescribed load for a 15-day period for the number of equipments supported. Units authorized additional prescribed loads will multiply the number of prescribed loads authorized by the quantity of repair parts reflected in the appropriate density column to determine the number of repair parts authorized.

(3) To determine allowances when supporting more than 100 of these equipments: First, divide the number of equipments supported by 100 by moving the decimal two spaces left; second, multiply the result by the quantity in the 51—100 density column. Example, authorized allowance for 51—100 equipments is 12; for 140 equipments,

multiply 12 by 1.40 or 16.80 rounded off to 17 parts required.

(4) Subsequent changes to allowances will be limited as follows: No change in the range of items is authorized. If additional items are considered necessary, recommendation should be forwarded to the U.S. Army Mobility Equipment Command for exception or revision to the allowance list. Revisions to the range of items authorized will be made by the U.S. Army Mobility Equipment Command based upon engineering experience, demand data, or TAERS information.

g. Thirty-Day DS/GS Maintenance Allowances.

Note. Allowances in GS column are for GS maintenance only.

(1) The allowance columns are divided into three subcolumns. Indicated in each subcolumn, opposite the first appearance of each item, is the total quantity of items authorized for the number of equipments supported. Subsequent appearances of the same item will have the letters "REF" in the applicable allowance column. To locate the referenced item, locate the FSN or reference number in the index. The earliest figure and item number is the referenced item. Items authorized for use as required but not for initial stockage are identified with an asterisk in the allowance column.

(2) The quantitative allowances for DS/GS levels of maintenance will represent initial stockage for a 30-day period for the number of equipments supported.

(3) To determine allowances when supporting more than 100 of these equipments: First, divide the number of equipments supported by 100 by moving the decimal two places left; second, multiply the result by the quantity in the 51—100 density column. Example, authorized allowance for 51—100 equipments is 40; for 150 equipments, multiply 40 by 1.50 or 60 parts required.

h. One-Year Allowance Per 100 Equipments/Contingency Planning Purposes. Indicates opposite the first appearance of each item the total quantity required for distribution and contingency planning purposes. The range of items indicates total quantities of all authorized items required to provide for adequate support of 100 equipments for one year.

i. Depot Maintenance Allowance Per 100 Equipments. (Not applicable.)

j. Illustration.

(1) *Figure number.* Indicates the figure number of the illustration in which the item is shown.

(2) *Item number.* Indicates the callout number used to reference the item in the illustration.

D-4. Special Information

a. Repair parts mortality has been based on 12 hours' operation per day.

b. Parts which require manufacture or assembly at a category higher than that authorized for installation will indicate in the source column the higher category.

d. The same illustrations are used to illustrate the repair parts in both organizational maintenance section and direct and general support maintenance section.

D-5. How to Locate Repair Parts

a. When Federal stock number or reference number is unknown:

(1) *First.* Using the table of contents, determine the assembly group within which the repair part belongs. This is necessary since illustrations are prepared for assembly groups, and listings are divided into the same groups.

(2) *Second.* Find the illustration covering the assembly group to which the repair part belongs.

(3) *Third.* Identify the repair part on the illustration and note the illustration figure and item number of the repair part.

(4) *Fourth.* Using the Repair Parts Listing, find the assembly group to which the repair part belongs and locate the illustration figure and item number noted on the illustration.

b. When Federal stock number or reference is known:

(1) *First.* Using the Index of Federal Stock Numbers and Reference Numbers, find the per-

tinent Federal stock number or reference number. This index is in ascending FSN sequence followed by a list of reference numbers in alphanumeric sequence, cross-referenced to the illustration figure number and item number.

(2) *Second.* Using the Repair Parts Listing, find the assembly group of the repair part and the illustration figure number and item number referenced in the Index of Federal Stock Numbers and Reference Numbers.

D-6. Abbreviations

- brsbrass
- degdegree(s)
- hex.hexagon
- in.inch(es)
- mtg.mounting(s)
- thk.thick(ness)

D-7. Federal Supply Codes for Manufacturers

<i>Codes</i>	<i>Manufacturer</i>
08484	Breeze Corporation. Inc.
14448.	Hammond Valve Corp.
30327.	Imperial-Eastman Corp.
37239	Lunkenheimer Co., The
41947	Mueller Brass Co.
43249.	Neptune Meter Co., Liquid Meter Div.
71129.	Bound Brook Bearing Corp of America
73957.	Groov-Pin Corp.
77122	Palnut Co.
79136.	Waldes Kohinoor, Inc.
79172.	Wallace and Tiernan, Inc.
89117	Penberthy Mfg. Co.
96906.	Military Standards

(1) FEDERAL STOCK NUMBER	(2) DESCRIPTION	(3) 15-DAY ORGANIZATIONAL MAINTENANCE ALLOWANCE			
		(a)	(b)	(c)	(d)
		1-5	6-20	21-50	51-100
	SECTION 11 - PRESCRIBED LOAD ALLOWANCE				
	GROUP 01 - WATER METER ASSEMBLY				
4610-428-1924	GLASS, REGISTER BOX		2	2	2
5330-428-1925	GASKET, REGISTER		2	2	2
	GROUP 02 - HYPOCHLORINATOR				
4610-424-2770	DIAPHRAGM, PUMPING HEAD		2	2	2
5330-247-3550	GASKET, BALANCING WATER VALVE				2
5330-247-4116	GASKET, PUMP BODY		2	2	2
5330-247-4159	GASKET, PRIMING PLUG				2
6685-492-7552	GASKET, FLOW CONTROLLER			2	2
	GROUP 03 - MISCELLANEOUS				
4610-424-2771	STRAINER		2	2	2
6685-492-7552	GASKET				2

(1) SMR CODE	(2) FEDERAL STOCK NUMBER	(3) DESCRIPTION REF NUMBER & MFR CODE	(4) UNJT OF MEAS USABLE ON CODE	(5) QTY INC IN UNIT	(6) 15-DAY ORGANIZATIONAL MAINTENANCE ALW				(7) ILLUS- TRATION	
					(a)	(b)	(c)	(d)	(a)	(b)
					1-5	6-20	21-50	51-100	FIG. NO.	ITEM NO.
		SECTION 111 - REPAIR PARTS FOR ORGANIZATIONAL MAINTENANCE								
		GROUP 01 - WATER METER ASSEMBLY								
P O R		METER, WATER ASSEMBLY UXB4923 (79172)	EA	1	*	*	*	*	D1	
X20		SCREW, MACHINE: COVER MTG S2 (43249)	EA	2					D1	1
P O	5330-428-1925	GASKET SR1B10 (43249)	EA	1	*	2	2	2	D1	3
X20		PIN, HINGE SR1B4 (43249)	EA	1					D3	1
X20		COVER, REGISTER SR1B3 (43249)	EA	1					D3	2
X20		BOX, REGISTER, LESS COVER SR1B5 (43249)	EA	1					D3	3
X20		RING, BOX SR1B6 (43249)	EA	1					D3	4
P O	4610-428-1924	GLASS, REGISTER BOX SR1B7 (43249)	EA	1	*	2	2	2	D3	5
X20		SPRING, RETAINER SR1B8 (43249)	EA	1					D3	6
		GROUP 02 - WATER PURIFICATION								
X20 R		AUTOMATIC HYPOCHLORINATOR A416121 (79172)	EA	1					D4	
P O	5310-058-3631	WASHER, FLAT: END PLATE MTG PC2247 (79172)	EA	8	*	*	*	*	D4	12
P O		PLUG, PIPE: MAIN CASTING PC288 (79172)	EA	2	*	*	*	*	D4	23
P O	4730-011-2578	PLUG, PIPE: MAIN CASTING PC633 (79172)	EA	1	*	*	*	*	D4	26
P O	4610-424-2770	DIAPHRAGM: PUMPING HEAD U4678 (79172)	EA	1	*	2	2	2	D4	29
X20	4610-424-2748	BODY, PUMP P12582 (79172)	EA	1					D4	30
P O	5330-247-4116	GASKET: PUMP BODY P12601 (79172)	EA	4	*	*	*	2	D4	31
X20	4610-371-4597	SEAT, POPPET VALVE: SOLUTION PUMP P12600 (79172)	EA	2					D4	32
X20		VALVE, POPPET: SOLUTION PUMP PXA12638 (79172)	EA	2					D4	33
X20	4610-424-2774	BODY, VALVE: SOLUTION U5334 (79172)	EA	2					D4	34
X20	5315-424-2717	PIN, TAPERED, HEADLESS: YOKE CLAMPING P11020 (79172)	EA	1					D4	35
X20	5305-424-2751	SCREW: YOKE CLAMPING P12598 (79172)	EA	1					D4	36
X20		YOKE, CLAMPING: PUMP BODY PXC12585 (79172)	EA	1					D4	37
X20		DISK, CLAMP: PUMP BODY PXE12583 (79172)	EA	1					D4	38

(1) SMR CODE	(2) FEDERAL STOCK NUMBER	(3) DESCRIPTION REF NUMBER & MFR CODE	(4) USABLE ON CODE	(5) UNIT OF MEAS	(6) QTY INC IN UNIT	(6) 15-DAY ORGANIZATIONAL MAINTENANCE ALW				(7) ILLUS- TRATION	
						(a)	(b)	(c)	(d)	(a)	(b)
						1-5	6-20	21-50	51-100	FIG. NO.	ITEM NO.
P O	5305-550-1310	BOLT, MACHINE MS90725-60 (96906)		EA	4	*	*	*	*	D9	14
X20		COVER, PROTECTIVE UXB7802 (79172)		EA	1					D9	15
P O	4730-277-5553	ELBOW, STREET P698 (79172)		EA	1	*	*	*	*	D9	17
M O		TUBE, PLASTIC RP52-4565SUB10 (79172) MANUFACTURE FROM: TUBE, PLASTIC, 8 FT REQUIRED, FSN 4710-709-0441		EA	1					D9	19
P O		CLAMP, LOOP QS200M16S (08484)		EA	1	*	*	*	*	D9	20
X20		MANIFOLD U15250 (79172)		EA	1					D9	21
X20		COUPLING, INLET P32863 (79172)		EA	1					D9	22
X20		VALVE, GLOBE 415 (14448)		EA	1					D9	23
X20		TUBE ASSEMBLY U15942 (79172)		EA	1					D9	24
P O		NIPPLE, PIPE P33941 (79172)		EA	1	*	*	*	*	D9	26
P O	4730-014-0674	NIPPLE, PIPE P627 (79172)		EA	1	*	*	*	*	D9	27
P O	4730-289-2870	TEE, BRASS P694 (79172)		EA	1	*	*	*	*	D9	28
P O		NIPPLE, HOSE PC7449 (79172)		EA	1	*	*	*	*	D9	29
X20		TOOL BOX UXA7801 (79172)		EA	1					D9	30
P O		NUT, PLAIN, HEXAGON; TOOL BOX MS35649-2252 (96906)		EA	4	*	*	*	*	D9	31
P O		WASHER, LOCK; TOOL BOX MS35338-44 (96906)		EA	4	*	*	*	*	D9	32
P O		SCREW, MACHINE; TOOL BOX PC7778 (79172)		EA	4	*	*	*	*	D9	33
P O	6685-492-7552	GASKET P2519 (79172)		EA	3	*	*	*	2	D9	36
M O		TUBE, PLASTIC RP52-4503 (79172) MANUFACTURE FROM: TUBE, PLASTIC, 22 IN. REQUIRED, FSN 4710-818-3476		EA	3					D9	37
P O		CLAMP, LOOP QS200M6S (08484)		EA	4	*	*	*	*	D9	38
M O		TUBE, PLASTIC RP52-4503 (79172) MANUFACTURE FROM: TUBE, PLASTIC, 48 IN. REQUIRED, FSN 4710-818-3476		EA	1					D9	39
M O		TUBE, PLASTIC RP52-4503 (79172) MANUFACTURE FROM: TUBE, PLASTIC, 66 IN. REQUIRED, FSN 4710-818-3476		EA	1					D9	40

(1) SMR CODE	(2) FEDERAL STOCK NUMBER	(3) DESCRIPTION REF NUMBER & MFR CODE	(4) USABLE ON CODE	(5) QTY INC IN UNIT	(6) 15-DAY ORGANIZATIONAL MAINTENANCE ALW				(7) ILLUS- TRATION	
					(a)	(b)	(c)	(d)	(a)	(b)
					1-5	6-20	21-50	51-100	FIG. NO.	ITEM NO.
X20		PLATE, CLAMPING: PUMP BODY PX12584 (79172)		EA 1					D4	39
X20	5306-424-2739	SCREW, EYE: END PLATE CLAMPING P11890 (79172)		EA 4					D4	40
X20	5315-276-3608	PIN, GROOVED, HEADLESS: BODY CLAMPING SCREW PC11901 (79172)		EA 1					D4	41
P O	5310-428-1329	NUT, CAP: CLAMPING END PLATE MTG PC6145 (79172)		EA 4	*	*	*	*	D4	42
P O	5330-247-4159	GASKET: PRIMING PLUG P12588 (79172)		EA 1	*	*	*	2	D4	43
P O	4610-424-2749	PLUG, PRIMING: PUMP BODY P12587 (79172)		EA 1	*	*	*	*	D4	44
X20	4610-428-1442	TUBE, DRAIN: PUMP BODY P12592 (79172)		EA 1					D4	45
P O	5330-247-3550	GASKET: BALANCING WATER VALVE P19338 (79172)		EA 1	*	*	*	2	D4	47
P O	6685-492-7552	GASKET: FLOW CONTROLLER P2519 (79172)		EA 2	*	2	2	2	D4	52
X20		TUBE ASSEMBLY: FLOW CONTROLLER TO REAR HOUSING UXA15955 (79172)		EA 1					D4	53
X20		CONTROLLER, FLOW UXA15948 (79172)		EA 1					D5	
X20		PLUG: FLOW CONTROLLER PXA34182 (79172)		EA 1					D5	1
X20		GASKET, LEAD, 1/32 IN. THK P24379 (79172)		EA 1					D5	2
P O		PLUG, PIPE 12181-8 (30327)		EA 1	*	*	*	*	D5	3
X20	4610-428-1946	VALVE, BALANCING UXA5262 (79172)		EA 1					D6	
P O	6685-264-3896	GAGE, PRESSURE U670 (79172)		EA 1	*	*	*	*	D6	3
P O	4730-428-1692	SCREEN, STRAINER P4129 (79172)		EA 1	*	*	*	*	D6	5
X20	4610-428-1942	BARREL ASSEMBLY UXA1554 (79172)		EA 1					D6	6
P O	5306-637-9675	BOLT, MACHINE: VALVE MTG MS35309-332 (96906)		EA 2	*	*	*	*	D6	12
X20	4610-496-3968	VALVE: PRESSURE REGULATING U7792 (79172)		EA 1					D6	
X20		LINE ASSEMBLY, INLET: PRESSURE VALVE COUPLING WJA7797 (79172)		EA 1					D6	11
GROUP 03 - MISCELLANEOUS										
P O		SCREW, CAP MS90725-58 (96906)		EA 2	*	*	*	*	D9	8
P O	5310-637-9541	WASHER, LOCK MS35338-46 (96906)		EA 6	*	*	*	*	D9	9
P O		WASHER, FLAT MS27183-15 (96906)		EA 6	*	*	*	*	D9	10
X20		COUPLING, OUTLET P32864 (79172)		EA 1					D9	13

(1) SMR CODE	(2) FEDERAL STOCK NUMBER	(3) DESCRIPTION REF NUMBER & MFR CODE	(4) USABLE ON CODE	(5) UNIT OF MEAS	(6) QTY INC IN UNIT	(6) 15-DAY ORGANIZATIONAL MAINTENANCE ALW				(7) ILLUS- TRATION	
						(a)	(b)	(c)	(d)	(a)	(b)
						1-5	6-20	21-50	51-100	FIG. NO.	ITEM NO.
P O	4820-640-6129	PETCOCK 118 (89117)		EA	1	*	*	*	*	D9	41
X20		TUBE ASSEMBLY U15943 (79172)		EA	1					D9	42
X20		BAG, HYPOCHLORITE PXA16589 (79172)		EA	1					D9	44
P O	4610-424-2771	STRAINER U11856 (79172)		EA	1	*	2	2	2	D9	45
P O		SCREW, MACHINE: PLATE MTG PC11328 (79172)		EA	4	*	*	*	*	D9	46
P O		WASHER, LOCK: PLATE MTG MS35333-38 (96906)		EA	4	*	*	*	*	D9	47
P O		NUT, PLAIN, HEXAGON: PLATE MTG MS35649-286 (96906)		EA	4	*	*	*	*	D9	48
X20		PLATE, IDENTIFICATION P45684 (79172)		EA	1					D9	49

(1) SMR CODE	(2) FEDERAL STOCK NUMBER	(3) DESCRIPTION USABLE ON CODE	(4) UNIT OF MEAS	(5) QTY INC IN UNIT	(6) 30-DAY DS MAINT ALLOWANCE			(7) 30-DAY GS MAINT ALLOWANCE			(8) 1-YR ALW PER 100 EQUIP CNTGY	(9) ILLUS- TRATION	
					(a)	(b)	(c)	(a)	(b)	(c)		(a)	(b)
					1-20	21-50	51-100	1-20	21-50	51-100		FIG. NO.	ITEM NO.
		SECTION V - REPAIR PARTS FOR DS, GS MAINTENANCE											
		GROUP 01 - WATER METER ASSEMBLY											
P O R		METER, WATER ASSEMBLY UXB423 (79172)	EA	1	*	*	*	*	*	*	5	D1	
X20		SCREW, MACHINE: COVER MTG S2 (43249)	EA	2								D1	1
P F	4610-428-1916	GEAR TRAIN S6D (43249)	EA	1	*	*	*	*	*	*	5	D1	2
P O	5330-428-1925	GASKET SR1B10 (43249)	EA	1	2	2	4	2	2	4	50	D1	3
X2F		ROD, SQUARE, BRASS: COUPLING P31227 (79172)	EA	1								D1	4
X2F		COUPLING, DISK P30393 (79172)	EA	2								D1	5
P F	5306-428-1878	BOLT, U: CHAMBER MTG P17558 (79172)	EA	2	*	*	*	*	*	*	*	D1	6
P F	5310-012-0214	WASHER, LOCK: U-BOLT MS35338-45 (96906)	EA	4	*	*	*	*	*	*	*	D1	7
P F	5310-176-8160	NUT, PLAIN, HEXAGON: U-BOLT MS51967-5 (96906)	EA	4	*	*	*	*	*	*	*	D1	8
P F	5305-010-1127	SCREW, MACHINE: CHAMBER PC746 (79172)	EA	2	*	*	*	*	*	*	*	D1	9
P F	5310-045-5206	COLLAR: CHAMBER SCREW P2985 (79172)	EA	2	2	2	2	2	2	2	25	D1	10
X2F		CHAMBER, MEASURING BB9 (43249)	EA	1								D1	11
X2F		BOLT: CAP MTG BB13B (43249)	EA	2								D1	12
X2F		LINING, PLASTIC: CHAMBER CAP BB13-3A (43249)	EA	1								D1	13
X2F		GASKET: CAP MTG BB13D (43249)	EA	1								D1	14
X2F		CAP, BOTTOM: CHAMBER BB13 (43249)	EA	1								D1	15
X2F		WASHER, FLAT: CAP MTG BB13C (43249)	EA	2								D1	16
X2F		NUT, PLAIN, HEXAGON: CAP MTG BB13A (43249)	EA	2								D1	17
X1		CASE, EXTENSION P32326 (79172)	EA	1								D2	1
X2F		BEARING, SLEEVE 191C0305 (71129)	EA	2								D2	2
P F	5310-496-3929	NUT, PLAIN, HEXAGON 6R32-4 (77122)	EA	2	*	*	*	*	*	*	*	D2	3
X2F		GEAR, SPUR MG14032 (79172)	EA	1								D2	4
X2F		GEAR, SPUR MG14040 (79172)	EA	1								D2	5
X2F		GEAR, BEVEL P30081 (79172)	EA	1								D2	6
X2F		SHAFT, SHOULDER P30083 (79172)	EA	1								D2	7

(1) SMR CODE	(2) FEDERAL STOCK NUMBER	(3) DESCRIPTION USABLE ON CODE	(4) UNIT OF MEAS	(5) QTY INC IN UNIT	(6) 30-DAY DS MAINT ALLOWANCE			(7) 30-DAY GS MAINT ALLOWANCE			(8) 1-YR ALW PER 100 EQUIP CNTGY	(9) ILLUS- TRATION	
					(a)	(b)	(c)	(a)	(b)	(c)		(a)	(b)
					1-20	21-50	51-100	1-20	21-50	51-100		FIG. NO.	ITEM NO.
X2F		BEARING, SLEEVE 191H (71129)	EA	1								D2	8
X2F		GEAR, BEVEL U14053 (79172)	EA	1								D2	9
X2F		SHAFT, SHOUDLER P30084 (79172)	EA	1								D2	10
X2F		PLATE, BEARING P30085 (79172)	EA	1								D2	11
P F		SCREW, MACHINE P742 (79172)	EA	2	*	*	*	*	*	*	*	D2	12
P F	5310-186-9340	WASHER, FLAT P6456 (79172)	EA	2	*	*	*	*	*	*	*	D2	13
P F		WASHER, LOCK MS35338-98 (96906)	EA	2	*	*	*	*	*	*	*	D2	14
X2F		OVERLOAD, RELEASE U13898 (79172)	EA	1								D2	15
X2F		STEM, DRIVE U7657 (79172)	EA	1								D2	16
X2F		KEY, DRIVE SHAFT P12812 (79172)	EA	2								D2	16A
X2F		COLLAR, SHAFT P12095 (79172)	EA	1								D2	16B
X2F		SHAFT, DRIVE P17265 (79172)	EA	1								D2	16C
X2F		PIN, TAPERED P19999 (79172)	EA	2								D2	17
X20		PIN, HINGE SR1B4 (43249)	EA	1								D3	1
X20		COVER, REGISTER SR1B3 (43249)	EA	1								D3	2
X20		BOX, REGISTER, LESS COVER SR1B5 (43249)	EA	1								D3	3
X20		RING, BOX SR1B6 (43249)	EA	1								D3	4
P O	4610-428-1924	GLASS: REGISTER BOX SR1B7 (43249)	EA	1	2	2	4	2	2	4	50	D3	5
X20		SPRING, RETAINER SR1B8 (43249)	EA	1								D3	6
GROUP 02 - WATER PURIFICATION													
X20 R		AUTOMATIC HYPOCHLORINATOR A416121 (79172)	EA	1								D4	
P F	5310-424-2746	NUT, PLAIN, CAP: STROKE CONTROL ADJUSTING SHAFT P12557 (79172)	EA	1	*	*	*	*	*	*	5	D4	1
X2F	4610-428-1873	HANDLE: STROKE CONTROL PXD12555 (79172)	EA	1								D4	2
P F	5305-012-5735	SETSCREW: INDICATOR PC5804 (79172)	EA	1	*	*	*	*	*	*	*	D4	3
X2F	4610-428-1874	POINTER: STROKE CONTROL PXC12556 (79172)	EA	1								D4	4
P F	5305-428-1335	SCREW, MACHINE: DIAL MTG PC707 (79172)	EA	2	*	*	*	*	*	*	*	D4	5

(1) SMR CODE	(2) FEDERAL STOCK NUMBER	(3) DESCRIPTION USABLE ON CODE REF NUMBER & MFR CODE	(4) UNIT OF MEAS	(5) QTY INC IN UNIT	(6) 30-DAY DS MAINT ALLOWANCE			(7) 30-DAY GS MAINT ALLOWANCE			(8) 1-YR ALW PER 100 EQUIP CNTGY	(9) ILLUS- TRATION	
					(a)	(b)	(c)	(a)	(b)	(c)		(a)	(b)
					1-20	21-50	51-100	1-20	21-50	51-100		FIG. NO.	ITEM NO.
X2F		PIN, GROOVED, HEADLESS: REAR HOUSING TO DIAL P30039 (79172)	EA	1								D4	6
X2F	4610-424-2721	DIAL: CONTROL P11504 (79172)	EA	1								D4	7
X2F	4610-424-2730	SPRING, HELICAL, COMPRESSION: STROKE CONTROL SHAFT P11518 (79172)	EA	1								D4	8
X2F	4610-424-2728	GLAND, PACKING: STROKE CONTROL P11516 (79172)	EA	1								D4	9
M F		PACKING P538 (79172) MANUFACTURE FROM: PACKING, 36 IN. REQUIRED, FSN 5330-559-6120	EA	1								D4	10
P F		BOLT, MACHINE: REAR HOUSING TO MAIN CASTING MS90725-67 (96906)	EA	4	*	*	*	*	*	*	*	D4	11
P O	5310-058-3631	WASHER, FLAT: END PLATE MTG PC2247 (79172)	EA	8	*	*	*	*	*	*	*	D4	12
X2F	3120-428-1752	BEARING UNIT: CAMSHAFT U5255 (79172)	EA	1								D4	13
X2F		SHAFT, SHOUDLER: CAMSHAFT P30392 (79172)	EA	1								D4	14
P F	5305-496-3916	SCREW, MACHINE: CAM BRACKET PC11559 (79172)	EA	2	*	*	*	*	*	*	*	D4	15
P F	5310-188-4182	WASHER, FLAT: CAM BRACKET TO REAR HOUSING PC5665 (79172)	EA	2	*	*	*	*	*	*	*	D4	16
X2F	4610-424-2722	CAM: REAR HOUSING P11505 (79172)	EA	1								D4	17
X2F	4610-428-1872	BRACKET, SUPPORT: CAM PXA12554 (79172)	EA	1								D4	18
X2F	4610-428-1871	HOUSING: REAR PXA12553 (79172)	EA	1								D4	19
X2F		PIN, TAPERED, HEADLESS: ADJUSTMENT GUIDE P23745 (79172)	EA	1								D4	20
X2F	4610-424-2727	SHAFT: STROKE CONTROL P11514 (79172)	EA	1								D4	21
P F	5310-424-2726	NUT, ROUND: STROKE CONTROL ADJUSTING P11513 (79172)	EA	1	*	*	*	*	*	*	5	D4	22
P O		PLUG, PIPE: MAIN CASTING PC288 (79172)	EA	2	*	*	*	*	*	*	*	D4	23
X2F	4610-496-3964	HOUSING, HYPOCHLORINATOR PXB12548 (79172)	EA	1								D4	25
P O	4730-011-2578	PLUG, PIPE: MAIN CASTING PC633 (79172)	EA	1	*	*	*	*	*	*	*	D4	26
X2F		STUD, DRIVE: NAMEPLATE MTG N00-3-16INLG (73957)	EA	2								D4	27
P O	4610-424-2770	DIAPHRAGM: PUMPING HEAD U4678 (79172)	EA	1	2	2	4	2	2	4	50	D4	29
X20	4610-424-2748	BODY, PUMP P12582 (79172)	EA	1								D4	30
P O	5330-247-4116	GASKET: PUMP BODY P12601 (79172)	EA	4	*	2	2	*	2	2	23	D4	31

(1) SMR CODE	(2) FEDERAL STOCK NUMBER	(3) DESCRIPTION USABLE ON CODE REF NUMBER & MFR CODE	(4) UNIT OF MEAS	(5) QTY INC IN UNIT	(6) 30-DAY DS MAINT ALLOWANCE			(7) 30-DAY GS MAINT ALLOWANCE			(8) 1-YR ALW PER 100 EQUIP CNTGY	(9) ILLUS- TRATION	
					(a)	(b)	(c)	(a)	(b)	(c)		(a) FIG. NO.	(b) ITEM NO.
					1-20	21-50	51-100	1-20	21-50	51-100			
X20	4610-371-4597	SEAT, POPPET VALVE: SOLUTION PUMP P12600 (79172)	EA	2								D4	32
X20		VALVE, POPPET; SOLUTION PUMP PXA12638 (79172)	EA	2								D4	33
X20	4610-424-2774	BODY, VALVE: SOLUTION U5334 (79172)	EA	2								D4	34
X20	5315-424-2717	PIN, TAPERED, HEADLESS; YOKE CLAMPING P11020 (79172)	EA	1								D4	35
X20	5305-424-2751	SCREW; YOKE CLAMPING P12598 (79172)	EA	1								D4	36
X20		YOKE, CLAMPING: PUMP BODY PXC12585 (79172)	EA	1								D4	37
X20		DISK, CLAMP; PUMP BODY PXE12583 (79172)	EA	1								D4	38
X20		PLATE, CLAMPING: PUMP BODY PXE12584 (79172)	EA	1								D4	39
X20	5306-424-2739	SCREW, EYE: END PLATE CLAMPING P11890 (79172)	EA	4								D4	40
X20	5315-276-3608	PIN, GROOVED, HEADLESS; BODY CLAMPING SCREW PC11901 (79172)	EA	1								D4	41
P O	5310-428-1329	NUT, CAP: CLAMPING END PLATE MTG PC6145 (79172)	EA	4	*	*	*	*	*	*	5	D4	42
P O	5330-247-4159	GASKET; PRIMING PLUG P12588 (79172)	EA	1	*	2	2	*	2	2	23	D4	43
P O	4610-424-2749	PLUG, PRIMING: PUMP BODY P12587 (79172)	EA	1	*	*	*	*	*	*	5	D4	44
X20	4610-428-1442	TUBE, DRAIN: PUMP BODY P12592 (79172)	EA	1								D4	45
P F	5307-428-1443	STUD; BODY PLATE PXA12599 (79172)	EA	4	*	*	*	*	*	*	5	D4	46
P O	5330-247-3550	GASKET; BALANCING WATER VALVE P19338 (79172)	EA	1	*	2	2	*	2	2	23	D4	47
P F		ELBOW; 45 DEG PC12514 (79172)	EA	1	*	*	*	*	*	*	*	D4	48
P F		NIPPLE, PIPE PC630 (79172)	EA	1	*	*	*	*	*	*	*	D4	49
P F	5310-428-1418	NUT, UNION; FLOW CONTROLLER PC11 (79172)	EA	2	*	*	*	*	*	*	5	D4	50
P F	4610-428-1667	NIPPLE, UNION; FLOW CONTROLLER PC230 (79172)	EA	2	*	*	*	*	*	*	5	D4	51
P O	6685-492-7552	GASKET; FLOW CONTROLLER P2519 (79172)	EA	2	2	2	2	2	2	2	23	D4	52
X20		TUBE ASSEMBLY; FLOW CONTROLLER TO REAR HOUSING UXA15955 (79172)	EA	1								D4	53
P F	4610-247-6037	PACKING, PREFORMED; PUMP SHAFT P11561 (79172)	EA	1	2	2	4	2	2	4	50	D4	54
X2F	4610-424-2733	RETAINER; SPRING P11549 (79172)	EA	1								D4	55
X2F		SPRING, HELICAL, COMPRESSION; MAIN HOUSING P44337 (79172)	EA	1								D4	56
X2F	4610-424-2729	GUIDE, SHAFT; PUMP P11517 (79172)	EA	1								D4	57

SWP CODE	2 FEDERAL STOCK NUMBER	(3) DESCRIPTION USABLE ON CODE	(4) UNIT OF MEAS	(5) QTY INC IN UNIT	(6) 30-DAY DS MAINT ALLOWANCE			(7) 30-DAY GS MAINT ALLOWANCE			(8) 1-YR ALW PER 100 EQUIP CNTGY	(9) ILLUS- TRATION	
					(a)	(b)	(c)	(a)	(b)	(c)		(a)	(b)
					1-20	21-50	51-100	1-20	21-50	51-100		FIG. NO.	ITEM NO.
P F	5315-424-2761	PIN, STRAIGHT: STOP PUMP SHAFT GUIDE P17789 (79172)	EA	1	2	2	2	2	2	2	25	D4	58
X2F	4610-424-2772	SHAFT, PUMP U4745 (79172)	EA	1								D4	59
X2F	4610-424-2735	SEAT: DIAPHRAGM VALVE P11552 (79172)	EA	1								D4	60
X2F	5315-428-1430	PIN, TAPERED: YOKE GUIDE P11551 (79172)	EA	1								D4	61
X2F		BEARING, SLEEVE P19348 (79172)	EA	2								D4	62
X2F		RING, RETAINING 5133-12C (79136)	EA	2								D4	63
X2F		SHAFT, STRAIGHT: YOKE BRACKET PIVOT P21476 (79172)	EA	1								D4	64
X2F		YOKE, DRIVING: STROKE CONTROL VALVE P19362 (79172)	EA	1								D4	65
X2F	4610-424-2719	BRACKET: ROLLER SUPPORT P11443 (79172)	EA	1								D4	66
P F	5305-011-3975	SCREW, MACHINE: ROLLER SUPPORT BRACKET TO YOKE PC7778 (79172)	EA	2	*	*	*	*	*	*	*	D4	67
P F	5305-042-6379	SCREW, MACHINE: RELIEF SPRING PC6977 (79172)	EA	2	*	*	*	*	*	*	*	D4	68
P F	4610-424-2745	RETAINER, SPRING: RELIEF P12355 (79172)	EA	1	*	*	*	*	*	*	5	D4	69
P F	4610-424-2724	SPRING, LEAF: RELIEF P11509 (79172)	EA	3	*	*	*	*	*	*	5	D4	70
P F	4610-428-1424	ROLLER: CAM P11510 (79172)	EA	1	*	*	*	*	*	*	5	D4	71
P F	5315-428-1425	SHAFT, STRAIGHT: CAM ROLLER P11511 (79172)	EA	1	*	2	2	*	2	2	20	D4	72
X2F	4610-428-1423	SUPPORT: ROLLER P11446 (79172)	EA	1								D4	73
X2F	4610-424-2720	LEVER: STROKE CONTROL VALVE P11503 (79172)	EA	1								D4	74
P F	4610-424-2732	DIAPHRAGM, VALVE: FLAT P11546 (79172)	EA	1	*	2	2	*	2	2	23	D4	75
P F	5330-424-2736	WASHER, FLAT: DIAPHRAGM BACKING P11553 (79172)	EA	1	*	*	*	*	*	*	*	D4	76
X2F	4610-428-1428	BUSHING, SLEEVE: DIAPHRAGM VALVE STEM P11520 (79172)	EA	1								D4	77
X2F	4610-424-2785	STEM, VALVE: PILOT U8269 (79172)	EA	1								D4	78
X2F	4610-428-1427	GUIDE: VALVE P11519 (79172)	EA	1								D4	79
X2F	4610-424-2731	SEAT: DIAPHRAGM VALVE P11521 (79172)	EA	1								D4	80
X2F	4610-424-2744	RETAINER, SEAT: VALVE SPRING P12354 (79172)	EA	1								D4	81
X20		CONTROLLER, FLOW UXA15948 (79172)	EA	1								D5	
X20		PLUG: FLOW CONTROLLER PXA34182 (79172)	EA	1								D5	1

(1) SMR CODE	(2) FEDERAL STOCK NUMBER	(3) DESCRIPTION USABLE ON CODE	(4) UNIT OF MEAS	(5) QTY INC IN UNIT	(6) 30-DAY DS MAINT ALLOWANCE			(7) 30-DAY GS MAINT ALLOWANCE			(8) 1-YR ALW PER 100 EQUIP CNTGY	(9) ILLUS- TRATION	
					(a)	(b)	(c)	(a)	(b)	(c)		(a)	(b)
					1-20	21-50	51-100	1-20	21-50	51-100		FIG. NO.	ITEM NO.
X20		GASKET, LEAD: 1/32 IN. THK P24379 (79172)	EA	1								D5	2
P O		PLUG, PIPE 12181-8 (30327)	EA	1	*	*	*	*	*	*	*	D5	3
P F		BOLT, MACHINE MS35309-333 (96906)	EA	6	*	*	*	*	*	*	*	D5	4
P F		WASHER, FLAT PC2475 (79172)	EA	6	*	*	*	*	*	*	*	D5	5
X2F		CAP PXA24378 (79172)	EA	1								D5	6
X2F		SEAT, VALVE: FLOW CONTROLLER P34186 (79172)	EA	1								D5	7
P F		DIAPHRAGM P25680 (79172)	EA	1	*	2	2	*	2	2	20	D5	8
X2F		PLATE, BACKING P11811 (79172)	EA	1								D5	9
X2F		SPRING, HELICAL: VALVE PIN P11816 (79172)	EA	1								D5	10
X2F		PIN, VALVE P11815 (79172)	EA	1								D5	11
X2F		RETAINER, SPRING P11813 (79172)	EA	1								D5	12
X2F		SPRING, HELICAL P11817 (79172)	EA	1								D5	13
P F		SCREW, MACHINE PC6261 (79172)	EA	1	*	*	*	*	*	*	*	D5	14
P F		GASKET P10901 (79172)	EA	1	*	*	*	*	*	*	*	D5	15
P F		GASKET, FIBRE P390 (79172)	EA	1	*	*	*	*	*	*	*	D5	16
X2F		ADAPTER PXA24381 (79172)	EA	1								D5	17
X2F		BODY, VALVE PXA24373 (79172)	EA	1								D5	18
X20	4610-428-1946	VALVE, BALANCING UXA5262 (79172)	EA	1								D6	
P F	4820-640-6129	PETCOCK: PRESSURE GAGE U614 (79172)	EA	1	*	2	2	*	2	2	23	D6	1
P F		LENS, PLASTIC: WATER PRESSURE GAGE XP918 (79172)	EA	1	*	*	*	*	*	*	5	D6	2
P O	6685-264-3896	GAGE, PRESSURE U670 (79172)	EA	1	*	*	*	*	*	*	5	D6	3
X1	4610-428-1876	HEAD, VALVE: STRAINER PXA12675 (79172)	EA	1								D6	4
P O	4730-428-1692	SCREEN, STRAINER P4129 (79172)	EA	1	*	*	*	*	*	*	5	D6	5
X20	4610-428-1942	BARREL ASSEMBLY UXA1554 (79172)	EA	1								D6	6
P F	4610-213-0256	DIAPHRAGM ASSEMBLY: WATER BALANCING VALVE U9326 (79172)	EA	1	*	2	2	*	2	2	23	D6	7
P F	4610-428-1412	SPRING, HELICAL: WATER BALANCING VALVE P10574 (79172)	EA	1	*	*	*	*	*	*	5	D6	9
X2F		STEM, VALVE: WATER BALANCING VALVE U9321 (79172)	EA	1								D6	10

(1) SMR CODE	(2) FEDERAL STOCK NUMBER	(3) DESCRIPTION USABLE ON CODE	(4) UNIT OF MEAS	(5) QTY INC IN UNIT	(6) 30-DAY DS MAINT ALLOWANCE			(7) 30-DAY GS MAINT ALLOWANCE			(8) 1-YR ALW PER 100 EQUIP CNTGY	(9) ILLUS- TRATION		
					(a)	(b)	(c)	(a)	(b)	(c)		(a)	(b)	
					1-20	21-50	51-100	1-20	21-50	51-100		FIG. NO.	ITEM NO.	
X1	4610-428-1875	BODY, VALVE: WATER BALANCING PXA12575 (79172)	EA	1								D6	11	
P O	5306-637-9675	BOLT, MACHINE: VALVE MTG MS35309-332 (96906)	EA	2	*	*	*	*	*	*	*	D6	12	
P F	5305-013-2345	BOLT, MACHINE: BODY TO HEAD MTG MS35309-338 (96906)	EA	4	*	*	*	*	*	*	*	D6	13	
P F	4510-428-1379	VALVE, GLOBE: RANGE ADJUSTING, 2 IN. UXB7864 (79172)	EA	1	*	*	*	*	*	*	*	5	D7	
X2F		NUT, LOCK: HANDLE WPP1369 (79172)	EA	1									D7	1
X2F		WASHER, FLAT: HANDLE	EA	1									D7	2
X2F		HANDLE WPP1368 (79172)	EA	1									D7	3
X2F		NUT, PLAIN, HEXAGON: PACKING WPP1367 (79172)	EA	1									D7	4
X2F		GLAND, PACKING WPP1366 (79172)	EA	1									D7	5
X2F		PACKING WPP1365 (79172)	EA	1									D7	6
X2F		RING: BONNET TO BODY, PACKING WPP1364 (79172)	EA	1									D7	7
X2F		BONNET WPP1363 (79172)	EA	1									D7	8
X2F		NUT, LOCK: DISK WPP1362 (79172)	EA	1									D7	9
X2F		STEM WPP1361 (79172)	EA	1									D7	10
X2F		WASHER, WAVE P32868 (79172)	EA	1									D7	11
X2F		PLUG, VALVE P34193 (79172)	EA	1									D7	12
X2F		SEAT, VALVE P18532 (79172)	EA	1									D7	13
X1		BODY WPP1360 (79172)	EA	1									D7	14
X20	4610-496-3968	VALVE: PRESSURE REGULATING U7792 (79172)	EA	1									D8	
P F	5310-012-0377	NUT, PLAIN, HEXAGON: FLANGE MTG MS51967-8 (96906)	EA	8	*	*	*	*	*	*	*	*	D8	1
P F	5305-637-4042	BOLT, MACHINE: TOP HOUSING TO BOTTOM MS90725-65 (96906)	EA	8	*	*	*	*	*	*	*	*	D8	3
P F		WASHER, FLAT: HOUSING MS27183-15 (96906)	EA	16	*	*	*	*	*	*	*	*	D8	4
X2F	4610-522-9783	FLANGE, DIAPHRAGM: TOP P9764 (79172)	EA	1									D8	5
P F	4610-428-1572	SPRING, HELICAL: COMPRESSION P17229 (79172)	EA	1	*	*	*	*	*	*	*	5	D8	6
P F	5305-017-9837	SCREW, CAP, HEXAGON HEAD: DIAPHRAGM PLATE P18543 (79172)	EA	4	*	*	2	*	*	2	10	D8	7	
X2F	4610-428-1581	LOCK PLATE, DIAPHRAGM: BACKING P17551 (79172)	EA	1									D8	8
X2F	4610-428-1596	RETAINER: SPRING P17885 (79172)	EA	1									D8	9

(1) SMR CODE	(2) FEDERAL STOCK NUMBER	(3) DESCRIPTION	(4) USABLE ON CODE	(5) QTY INC IN UNIT	(6) 30-DAY DS MAINT ALLOWANCE			(7) 30-DAY GS MAINT ALLOWANCE			(8) 1-YR ALW PER 100 EQUIP CNTGY	(9) ILLUS- TRATION	
					(a)	(b)	(c)	(a)	(b)	(c)		(a)	(b)
					1-20	21-50	51-100	1-20	21-50	51-100		FIG. NO.	ITEM NO.
P F		DIAPHRAGM P9767 (79172)	EA	1	*	*	*	*	*	*	5	D8	10
X20		LINE ASSEMBLY, INLET: PRESSURE VALVE COUPLING WUA7797 (79172)	EA	1								D8	11
X2F	4610-784-8893	FLANGE, DIAPHRAGM: BOTTOM P9763 (79172)	EA	1								D8	12
X2F	4610-428-1579	GUIDE, VALVE: STEM P17549 (79172)	EA	1								D8	13
P F	5310-428-1584	NUT, LOCK: ADJUSTING SCREW 14 (37239)	EA	1	*	*	*	*	*	*	*	D8	14
P F		BOLT, MACHINE: STEM ADJUSTING P16823 (79172)	EA	1	*	*	*	*	*	*	*	D8	15
P F		NUT, PLAIN, HEXAGON P16543 (79172)	EA	1	*	*	*	*	*	*	*	D8	16
X2F	4610-428-1580	STEM, VALVE: REGULATING P17550 (79172)	EA	1								D8	17
P F	4610-428-1583	DISK: VALVE 12 (37239)	EA	1	*	*	*	*	*	*	5	D8	18
P F	4610-428-1582	RING, SEAT: REGULATING VALVE 13 (37239)	EA	1	*	*	*	*	*	*	5	D8	19
X2F	4610-428-1587	SHIM: VALVE SEAT, 1/64 IN. THK P17687 (79172) (AS REQUIRED)	EA									D8	20
X2F		SHIM: VALVE SEAT, 1/52 IN. THK P17685 (79172) (AS REQUIRED)	EA									D8	20
X2F	4610-428-1298	BODY, VALVE PXA9772 (79172)	EA	1								D8	21
		GROUP 03 - MISCELLANEOUS											
X2F		ADAPTER, METER P17557 (79172)	EA	2								D9	1
X2F		FRAME UXA7800 (79172)	EA	1								D9	2
X2F		COUPLING, UNIT U14029 (79172)	EA	4								D9	3
P F R		METER, WATER UXB4923 (79172)	EA	1	*	*	*	*	*	*	5	D9	4
M F		TUBE, COPPER RC52-4334 (79172) MANUFACTURE FROM:	FT	1								D9	5
		TUBE, COPPER, 18 IN. REQUIRED, FSN 4710-289-5945											
P F		ELBOW: 90 DEG A1530 (41947)	EA	4	*	*	*	*	*	*	*	D9	6
X2F		SHIM P18588 (79172)	EA	6								D9	7
P O		SCREW, CAP MS90725-58 (96906)	EA	2	*	*	*	*	*	*	*	D9	8
P O	5310-637-9541	WASHER, LOCK MS35338-46 (96906)	EA	6	*	*	*	*	*	*	*	D9	9
P O		WASHER, FLAT MS27183-15 (96906)	EA	6	*	*	*	*	*	*	*	D9	10
X2F		ADAPTER, TUBE MS35921-66 (96906)	EA	1								D9	11

(1) SWR CODE	(2) FEDERAL STOCK NUMBER	(3) DESCRIPTION USABLE ON CODE	(4) UNIT OF MEAS	(5) QTY INC IN UNIT	(6) 30-DAY DS MAINT ALLOWANCE			(7) 30-DAY GS MAINT ALLOWANCE			(8) 1-YR ALW PER 100 EQUIP CNTGY	(9) ILLUS- TRATION	
					(a)	(b)	(c)	(a)	(b)	(c)		(a)	(b)
					1-20	21-50	51-100	1-20	21-50	51-100		FIG. NO.	ITEM NO.
X2F		NIPPLE, PIPE P18084 (79172)	EA	1								D9	12
X20		COUPLING, OUTLET P32864 (79172)	EA	1								D9	13
P O	5305-550-1310	BOLT, MACHINE MS90725-60 (96906)	EA	4	*	*	*	*	*	*	*	D9	14
X20		COVER, PROTECTIVE UXB7802 (79172)	EA	1								D9	15
X2F		CONNECTOR, PIPE, HOSE PC3353 (79172)	EA	1								D9	16
P O	4730-277-5553	ELBOW, STREET P698 (79172)	EA	1	*	*	*	*	*	*	*	D9	17
P F	4730-277-7051	BUSHING, REDUCER 110B1-4-1-8 (30327)	EA	2	*	*	*	*	*	*	*	D9	18
M O		TUBE, PLASTIC RP52-4565SUB10 (79172) MANUFACTURE FROM: TUBE, PLASTIC, 8 FT REQUIRED, FSN 4710-709-0441	EA	1								D9	19
P O		CLAMP, LOOP QS200M16S (08484)	EA	1	*	*	*	*	*	*	*	D9	20
X20		MANIFOLD U15250 (79172)	EA	1								D9	21
X20		COUPLING, INLET P32863 (79172)	EA	1								D9	22
X20		VALVE, GLOBE 415 (14448)	EA	1								D9	23
X20		TUBE ASSEMBLY U15942 (79172)	EA	1								D9	24
X2F		CONNECTOR, HOSE U3758 (79172)	EA	1								D9	25
P O		NIPPLE, PIPE P33941 (79172)	EA	1	*	*	*	*	*	*	*	D9	26
P O	4730-014-0674	NIPPLE, PIPE P627 (79172)	EA	1	*	*	*	*	*	*	*	D9	27
P O	4730-289-2870	TEE, BRASS P694 (79172)	EA	1	*	*	2	*	*	2	10	D9	28
P O		NIPPLE, HOSE PC7449 (79172)	EA	1	*	*	*	*	*	*	*	D9	29
X20		TOOL BOX LXA7801 (79172)	EA	1								D9	30
P O		NUT, PLAIN, HEXAGON; TOOL BOX MS35649-2252 (96906)	EA	4	*	*	*	*	*	*	*	D9	31
P O		WASHER, LOCK; TOOL BOX MS35338-44 (96906)	EA	4	*	*	*	*	*	*	*	D9	32
P O		SCREW, MACHINE; TOOL BOX PC7778 (79172)	EA	4	*	*	*	*	*	*	*	D9	33
P F	5310-482-1418	NUT, UNION PC11 (79172)	EA	4	*	*	*	*	*	*	5	D9	34
P F	4610-428-1667	NIPPLE, UNION PC230 (79172)	EA	3	*	*	*	*	*	*	5	D9	35
P O	6685-492-7552	GASKET P2519 (79172)	EA	3	*	2	2	*	2	2	23	D9	36

(1) SMR CODE	(2) FEDERAL STOCK NUMBER	(3) DESCRIPTION USABLE ON CODE REF NUMBER & MFR CODE	(4) UNIT OF MEAS	(5) QTY INC IN UNIT	(6) 30-DAY DS MAINT ALLOWANCE			(7) 30-DAY GS MAINT ALLOWANCE			(8) 1-YR ALW PER 100 EQUIP CNTGY	(9) ILLUS- TRATION	
					(a)	(b)	(c)	(a)	(b)	(c)		(a)	(b)
					1-20	21-50	51-100	1-20	21-50	51-100		FIG. NO.	ITEM NO.
M O		TUBE, PLASTIC RP52-4503 (79172) MANUFACTURE FROM: TUBE, PLASTIC, 22 IN. REQUIRED, FSN 4710-818-3476	EA	3								D9	37
P O		CLAMP, LOOP QS200M6S (08484)	EA	4	*	*	*	*	*	*	*	D9	38
M O		TUBE, PLASTIC RP52-4503 (79172) MANUFACTURE FROM: TUBE, PLASTIC, 48 IN. REQUIRED, FSN 4710-818-3476	EA	1								D9	39
M O		TUBE, PLASTIC RP52-4503 (79172) MANUFACTURE FROM: TUBE, PLASTIC, 66 IN. REQUIRED, FSN 4710-818-3476	EA	1								D9	40
P O	4820-640-6129	PETCOCK 118 (89117)	EA	1	*	*	*	*	*	*	*	D9	41
X20		TUBE ASSEMBLY U15943 (79172)	EA	1								D9	42
P F	4610-428-1420	NIPPLE, UNION PC111 (79172)	EA	1	*	*	*	*	*	*	5	D9	43
X20		BAG, HYPOCHLORITE PXA16589 (79172)	EA	1								D9	44
P O	4610-424-2771	STRAINER U11856 (79172)	EA	1	2	2	4	2	2	4	50	D9	45
P O		SCREW, MACHINE: PLATE MTG PC11328 (79172)	EA	4	*	*	*	*	*	*	*	D9	46
P O		WASHER, LOCK: PLATE MTG MS35333-38 (96906)	EA	4	*	*	*	*	*	*	*	D9	47
P O		NUT, PLAIN, HEXAGON: PLATE MTG MS35649-286 (96906)	EA	4	*	*	*	*	*	*	*	D9	48
X20		PLATE, IDENTIFICATION P45684 (79172)	EA	1								D9	49

**Section VII. INDEX FEDERAL STOCK NUMBER AND REFERENCE NUMBER
CROSS-REFERENCE TO FIGURE AND ITEM NUMBER**

<u>STOCK NUMBER</u>	<u>FIGURE No.</u>	<u>ITEM No.</u>	<u>STOCK NUMBER</u>	<u>FIGURE No.</u>	<u>ITEM No.</u>
3120-428-1752	D4	13	4610-496-3964	D4	25
4510-428-1379	D7		4610-496-3968	D8	
4610-213-0256	D6	7	4610-522-9783	D8	5
4610-247-6037	D4	54	4610-784-8893	D8	12
4610-371-4597	D4	32	4730-011-2578	D4	26
4610-424-2719	D4	66	4730-014-0674	D9	27
4610-424-2720	D4	74	4730-277-5553	D9	17
4610-424-2721	D4	7	4730-277-7051	D9	18
4610-424-2722	D4	17	4730-289-2870	D9	28
4610-424-2724	D4	70	4730-428-1692	D6	5
4610-424-2727	D4	21	4820-640-6129	D6	1
4610-424-2728	D4	9		D9	41
4610-424-2729	D4	57	5305-010-1127	D1	9
4610-424-2730	D4	8	5305-011-3975	D4	67
4610-424-2731	D4	80	5305-012-5735	D4	3
4610-424-2732	D4	75	5305-013-2345	D6	13
4610-424-2733	D4	55	5305-017-9837	D8	7
4610-424-2735	D4	60	5305-042-6379	D4	68
4610-424-2744	D4	81	5305-424-2751	D4	36
4610-424-2745	D4	69	5305-428-1335	D4	3
4610-424-2748	D4	30	5305-496-3916	D4	15
4610-424-2749	D4	44	5305-550-1310	D9	14
4610-424-2771	D9	45	5305-637-4042	D8	3
4610-424-2772	D4	59	5306-424-2739	D4	40
4610-424-2774	D4	34	5306-428-1878	D1	6
4610-424-2785	D4	78	5306-637-9675	D6	12
4610-428-1298	D8	21	5307-428-1443	D4	46
4610-428-1312	D6	9	5310-012-0214	D1	7
4610-428-1420	D9	43	5310-012-0377	D8	1
4610-428-1423	D4	73	5310-045-5206	D1	10
4610-428-1424	D4	71	5310-058-3637	D4	12
4610-428-1427	D4	79	5310-176-8160	D1	8
4610-428-1428	D4	77	5310-186-9340	D2	13
4610-428-1436	D6	8	5310-188-4182	D4	16
4610-428-1442	D4	45	5310-424-2726	D4	22
4610-428-1572	D8	6	5310-424-2746	D4	1
4610-428-1579	D8	13	5310-428-1329	D4	42
4610-428-1580	D8	17	5310-428-1418	D4	50
4610-428-1581	D8	8	5310-428-1584	D8	14
4610-428-1582	D8	19	5310-482-1418	D9	34
4610-428-1583	D8	18	5310-496-3929	D2	3
4610-428-1587	D8	20	5310-637-9541	D9	9
4610-428-1596	D8	9	5315-276-3608	D4	41
4610-428-1667	D4	51	5315-424-2717	D4	35
	D9	35	5315-424-2761	D4	58
4610-428-1871	D4	19	5315-428-1425	D4	72
4610-428-1872	D4	18	5315-428-1430	D4	61
4610-428-1873	D4	2	5330-247-3550	D4	47
4610-428-1874	D4	4	5330-247-4116	D4	35
4610-428-1875	D6	11	5330-247-4159	D4	43
4610-428-1876	D4	4	5330-424-2736	D4	76
4610-428-1916	D1	2	5330-428-1925	D1	3
4610-428-1924	D3	5	6685-264-3896	D6	3
4610-428-1942	D6	6	6685-492-7552	D4	52
4610-428-1946	D6			D9	36

**Section VII. INDEX-FEDERAL STOCK NUMBER AND REFERENCE NUMBER
CROSS-REFERENCE TO FIGURE AND ITEM NUMBER**

<u>REFERENCE No.</u>	<u>Mfr CODE</u>	<u>FIG No.</u>	<u>ITEM No.</u>	<u>REFERENCE No.</u>	<u>Mfr CODE</u>	<u>FIG No.</u>	<u>ITEM No.</u>
A1530	41947	09	6	P11504	79172	04	7
A416121	79172	04		P11509	79172	04	70
BB13	43249	01	15	P11510	79172	04	71
BB13A	43249	01	17	P11511	79172	04	72
BB13B	43249	01	12	P11513	79172	04	22
BB13C	43249	01	16	P11514	79172	04	21
BB13D	43249	01	14	P11516	79172	04	9
BB13-3A	43249	01	13	P11517	79172	04	57
BB9	43249	01	11	P11518	79172	04	8
MG14032	79172	02	4	P11519	79172	04	79
MG14040	79172	02	5	P11520	79172	04	77
MS27183-15	96906	08	4	P11521	79172	04	80
	96906	09	10	P11546	79172	04	75
MS35309-332	96906	06	12	P11549	79172	04	55
MS35309-333	96906	05	4	P11551	79172	04	61
MS35309-338	96906	06	13	P11552	79172	04	60
MS35333-38	96906	09	47	P11553	79172	04	76
MS35338-44	96906	09	32	P11561	79172	04	54
MS35338-45	96906	01	7	P11811	79172	05	9
MS35338-46	96906	09	9	P11813	79172	05	12
MS35338-98	96906	02	14	P11815	79172	05	11
MS35649-2252	96906	09	31	P11816	79172	05	10
MS35649-286	96906	09	48	P11817	79172	05	13
MS35921-66	96906	09	11	P11890	79172	04	40
MS51967-5	96906	01	8	P12095	79172	02	168
MS51967-8	96906	08	1	P12354	79172	04	81
MS90725-58	96906	09	8	P12355	79172	04	69
MS90725-60	96906	09	14	P12557	79172	04	1
MS90725-65	96906	08	3	P12582	79172	04	30
MS90725-67	96906	04	11	P12587	79172	04	44
NOO-3-161NLG	73957	04	27	P12588	79172	04	43
PC11	79172	04	50	P12592	79172	04	45
	79172	09	34	P12598	79172	04	36
PC111	79172	09	43	P12600	79172	04	32
PC11328	79172	09	46	P12601	79172	04	31
PC11505	79172	04	17	P12812	79172	02	16A
PC11559	79172	04	15	P13227	79172	01	4
PC11901	79172	04	41	P16033	79172	08	15
PC12514	79172	04	48	P17229	79172	08	6
PC2247	79172	04	12	P17265	79172	02	16C
PC230	79172	09	35	P17549	79172	08	13
	79172	04	51	P17550	79172	08	17
PC2475	79172	05	5	P17551	79172	08	8
PC288	79172	04	23	P17557	79172	09	1
	79172	05	2	P17558	79172	01	6
PC3353	79172	09	16	P17685	79172	08	20
PC5665	79172	04	16	P17789	79172	04	58
PC5804	79172	04	3	P17867	79172	08	15
PC6145	79172	04	42	P17885	79172	08	9
PC6261	79172	05	14	P18084	79172	09	12
PC630	79172	04	49	P18532	79172	07	13
PC633	79172	04	26	P18543	79172	08	7
PC6977	79172	04	68	P18588	79172	09	7
PC707	79172	04	5	P19338	79172	04	47
PC7449	79172	09	29	P19348	79172	04	62
PC746	79172	01	9	P19362	79172	04	65
PC7778	79172	09	33	P19999	79172	02	17
	79172	04	67	P21476	79172	04	64
PXA12553	79172	04	19	P23745	79172	04	20
PXA12554	79172	04	18	P24379	79172	05	2
PXA12575	79172	06	11	P2519	79172	04	52
PXA12599	79172	04	46		79172	09	36
PXA12638	79172	04	33	P25680	79172	05	8
PXA12675	79172	06	4	P2905	79172	01	10
PXA16589	79172	09	44	P30039	79172	04	6
PXA24373	79172	05	18	P30081	79172	02	6
PXA24378	79172	05	6	P30083	79172	02	7
PXA24381	79172	05	17	P30084	79172	02	10
PXA34182	79172	05	1	P30085	79172	02	11
PXA9772	79172	08	21	P30392	79172	04	14
PXB12548	79172	04	25	P30393	79172	01	5
PXC12556	79172	04	4	P32326	79172	02	1
PXC12585	79172	04	37	P32863	79172	09	22
PXD12555	79172	04	2	P32864	79172	09	13
PXE12583	79172	04	38	P32868	79172	07	11
PXE12584	79172	04	39	P33941	79172	09	26
P10574	79172	05	9	P34186	79172	05	7
P10901	79172	05	15	P34193	79172	07	12
P11020	79172	04	35	P390	79172	05	16
P11443	79172	04	66	P4129	79172	06	5
P11446	79172	04	73	P44337	79172	04	56
P11503	79172	04	74	P45684	79172	09	49

**Section VII. INDEX - FEDERAL STOCK NUMBER AND REFERENCE NUMBER
CROSS-REFERENCE TO FIGURE AND ITEM NUMBER**

<u>REFERENCE No.</u>	<u>Mfg CODE</u>	<u>FIG No.</u>	<u>ITEM No.</u>	<u>REFERENCE No.</u>	<u>Mfg CODE</u>	<u>FIG No.</u>	<u>ITEM No.</u>
PK6368	79172	D8	16				
P538	79172	D4	10				
P627	79172	D9	27				
P6456	79172	D2	13				
P694	79172	D9	28				
P698	79172	D9	17				
P742	79172	D2	12				
P9763	79172	D8	12				
P9764	79172	D8	5				
P9767	79172	D8	10				
QS200M16S	08484	D9	20				
QS200M6S	08484	D9	38				
RC52-4334	79172	D9	5				
RF52-4503	79172	D9	37				
	79172	D9	39				
	79172	D9	40				
RF52-4565SUB10	79172	D9	19				
SR1B10	43249	D1	3				
SR1B3	43249	D3	1				
SR1B4	43249	D3	2				
SR1B5	43249	D3	3				
SR1B6	43249	D3	4				
SR1B7	43249	D3	5				
SR1B8	43249	D3	6				
S2	43249	D1	1				
S60	43249	D1	2				
UXA1554	79172	D6	6				
UXA15948	79172	D5					
UXA15955	79172	D4	53				
UXA5262	79172	D6					
UXA7800	79172	D9	2				
UXA7801	79172	D9	30				
UXB4923	79172	D9	4				
UXB4923	79172	D1					
UXB7802	79172	D9	15				
UXB7864	79172	D7					
U11856	79172	D9	45				
U13898	79172	D2	15				
U14029	79172	D9	3				
U14053	79172	D2	9				
U15250	79172	D9	21				
U15942	79172	D9	24				
U15943	79172	D9	42				
U3758	79172	D9	25				
U4678	79172	D4	29				
U4745	79172	D4	59				
U5255	79172	D4	13				
U5334	79172	D4	34				
U614	79172	D6	1				
U670	79172	D6	3				
U7657	79172	D2	16				
U7792	79172	D8					
U8269	79172	D4	78				
U9321	79172	D6	10				
U9326	79172	D6	7				
WPP1360	79172	D7	14				
WPP1361	79172	D7	10				
WPP1362	79172	D7	9				
WPP1363	79172	D7	8				
WPP1364	79172	D7	7				
WPP1365	79172	D7	6				
WPP1366	79172	D7	5				
WPP1367	79172	D7	4				
WPP1368	79172	D7	3				
WPP1369	79172	D7	1				
WUA7797	79172	D8	11				
XP918	79172	D6	2				
110B1-4-1-8	30327	D9	18				
118	89117	D9	41				
12	37239	D8	18				
13	37239	D8	19				
14	37239	D8	14				
191C0305	71129	D2	2				
191H	71129	D2	8				
415	14448	D9	23				
5133-12C	79136	D4	63				
6R32-4	77122	D2	3				

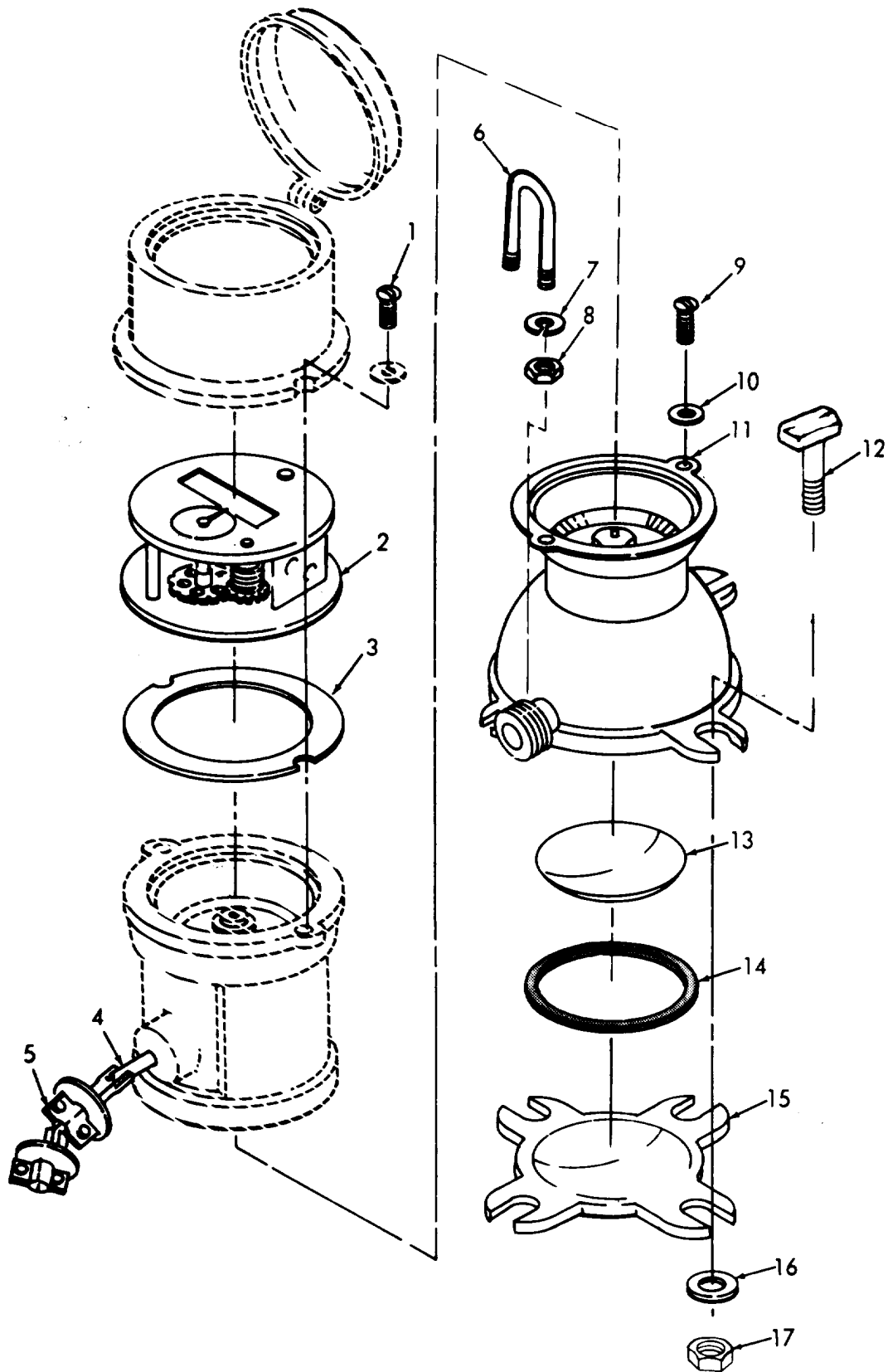

ME 4610-210-14/D-1

Figure D-1. Water Meter

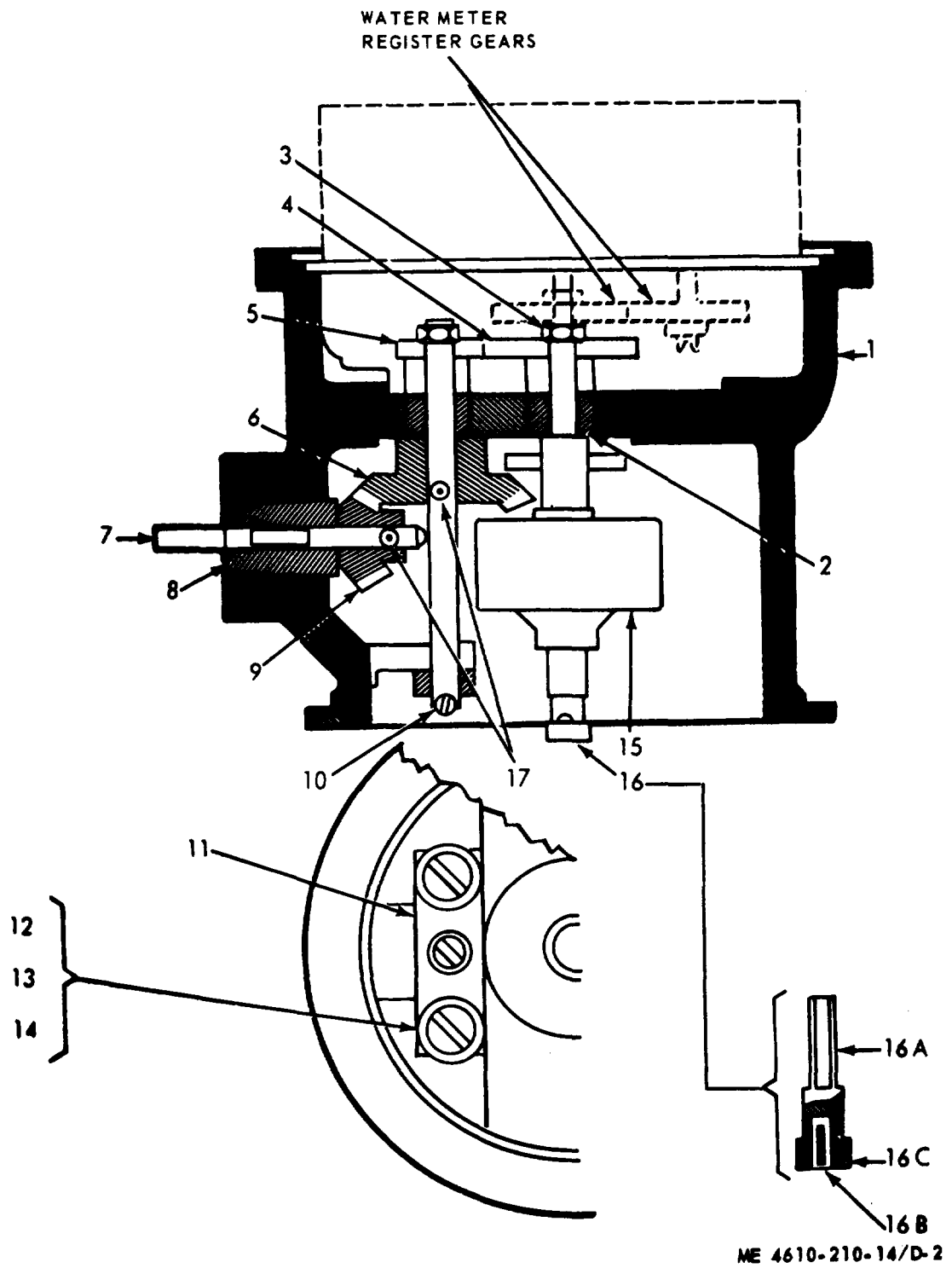
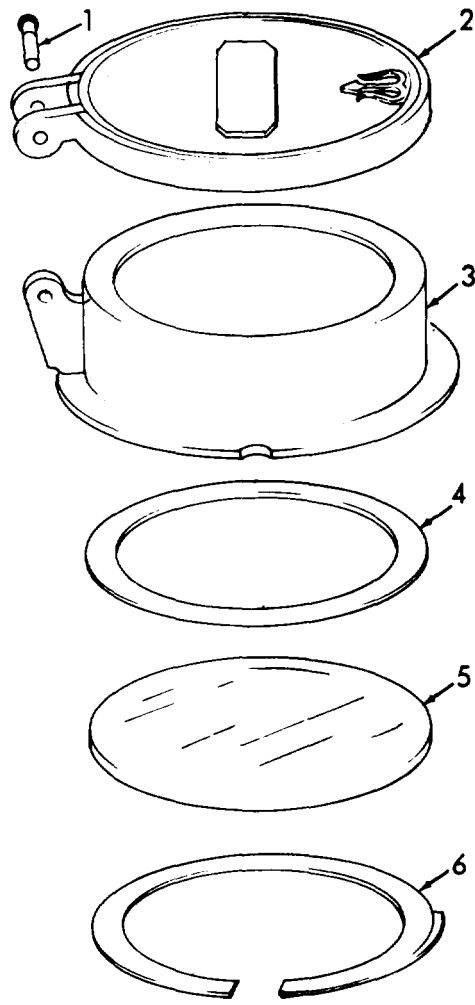
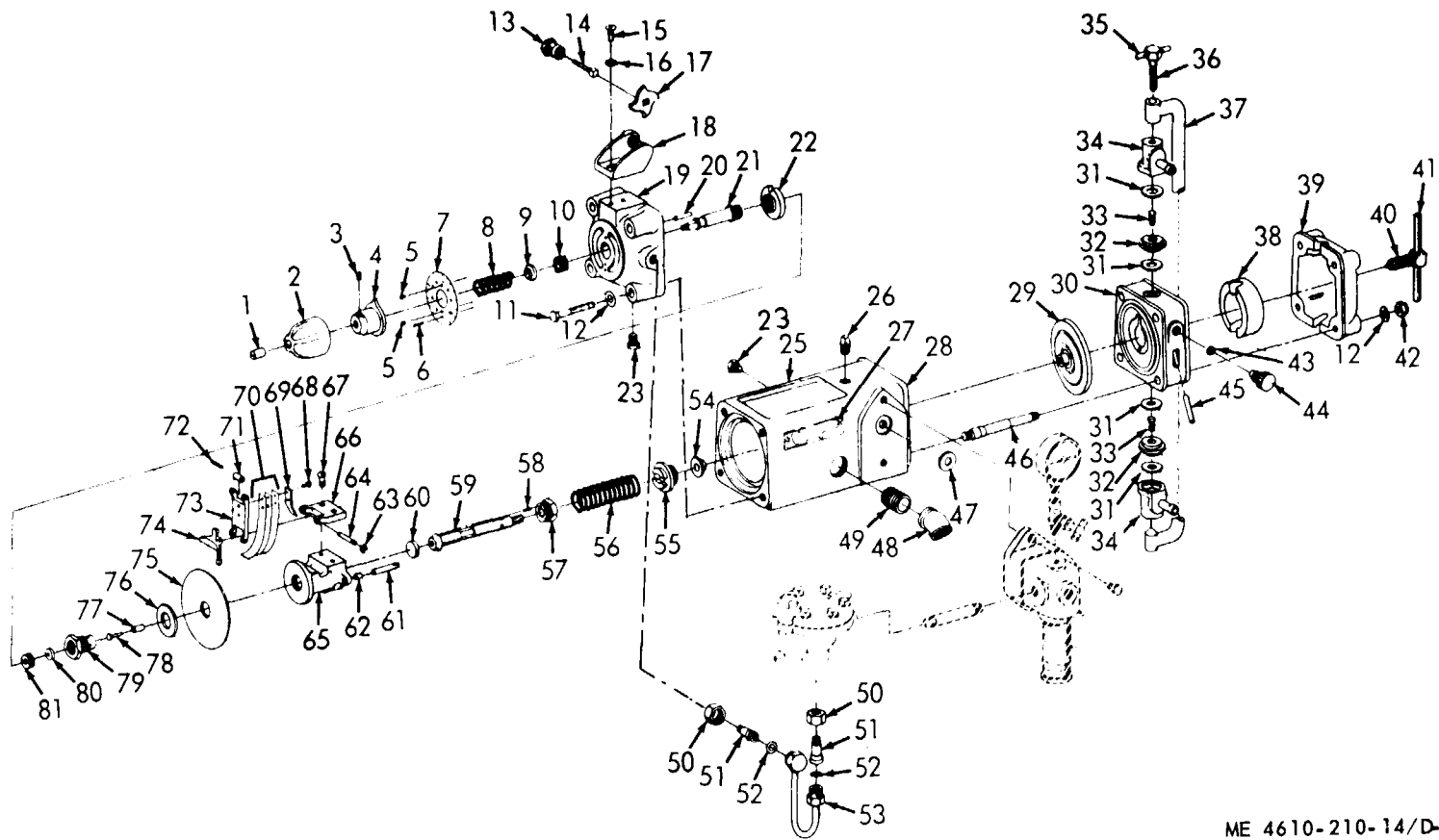

Figure D-2. Extension Case, Cross Section



ME 4610-210-14/D-3

Figure D-3. Register Box



ME 4610-210-14/D-4

Figure D-4. Hypochlorinator

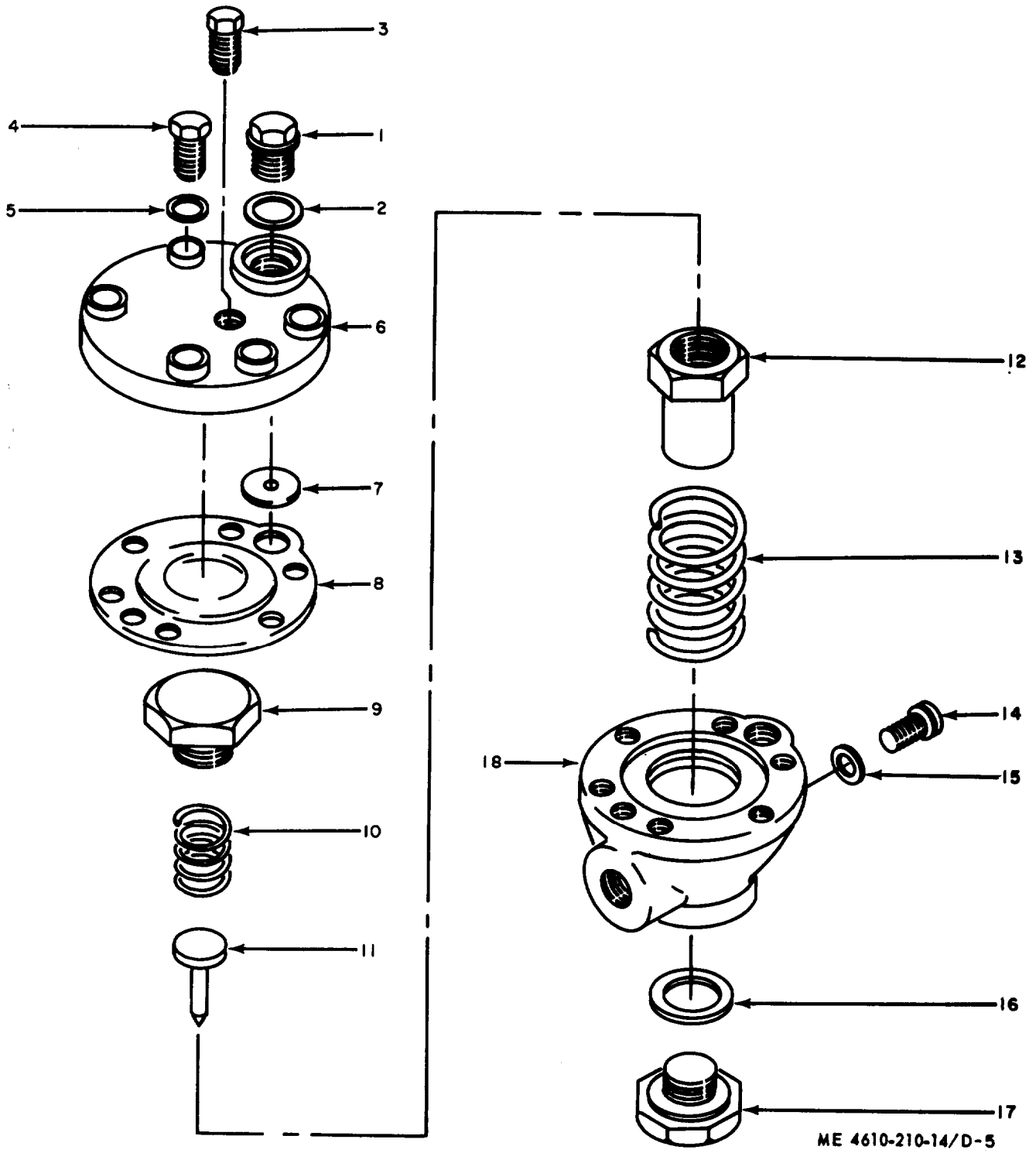
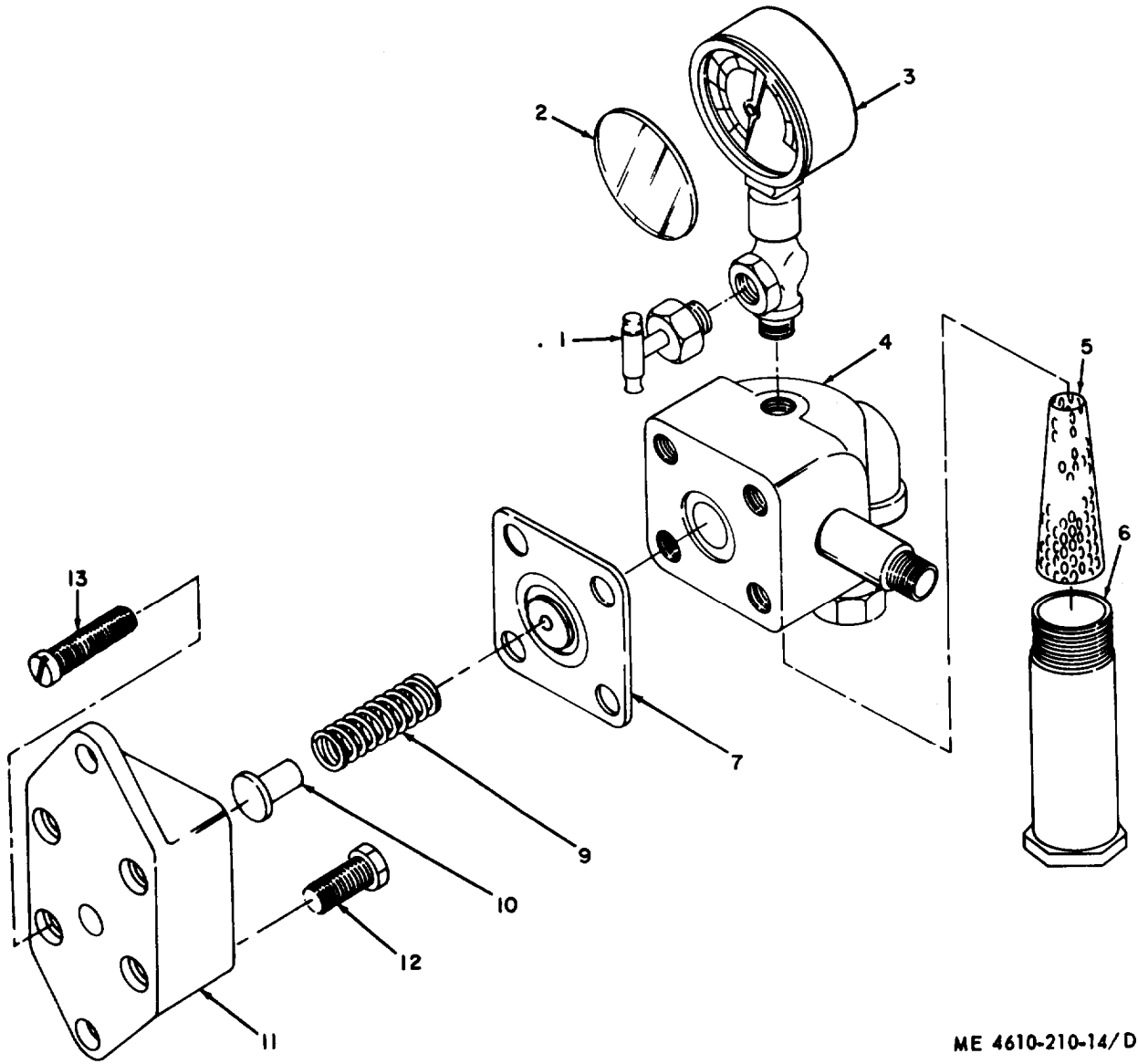

Figure D-5. Flow Controller



ME 4610-210-14/D-6

Figure D-6. Balancing Water Valve

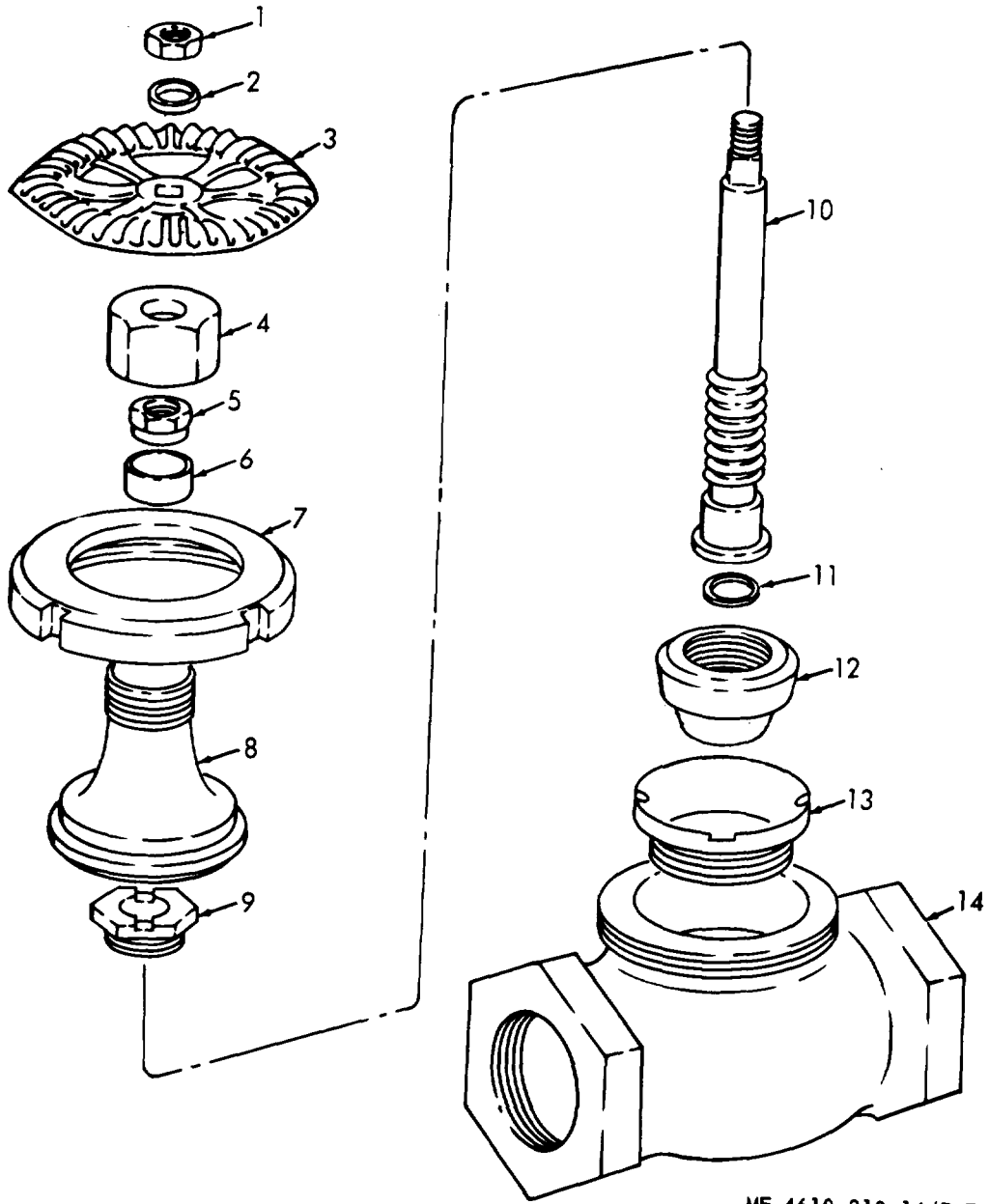
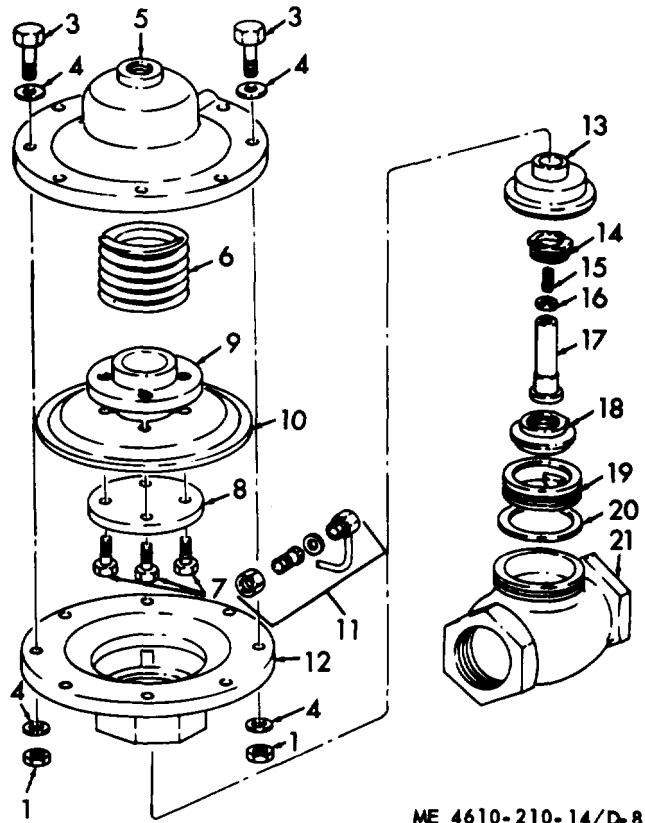

Figure D-7. Range Adjusting Valve

ME 4610-210-14/D-7



ME 4610-210-14/D-8

Figure D-8. Pressure Regulating Valve

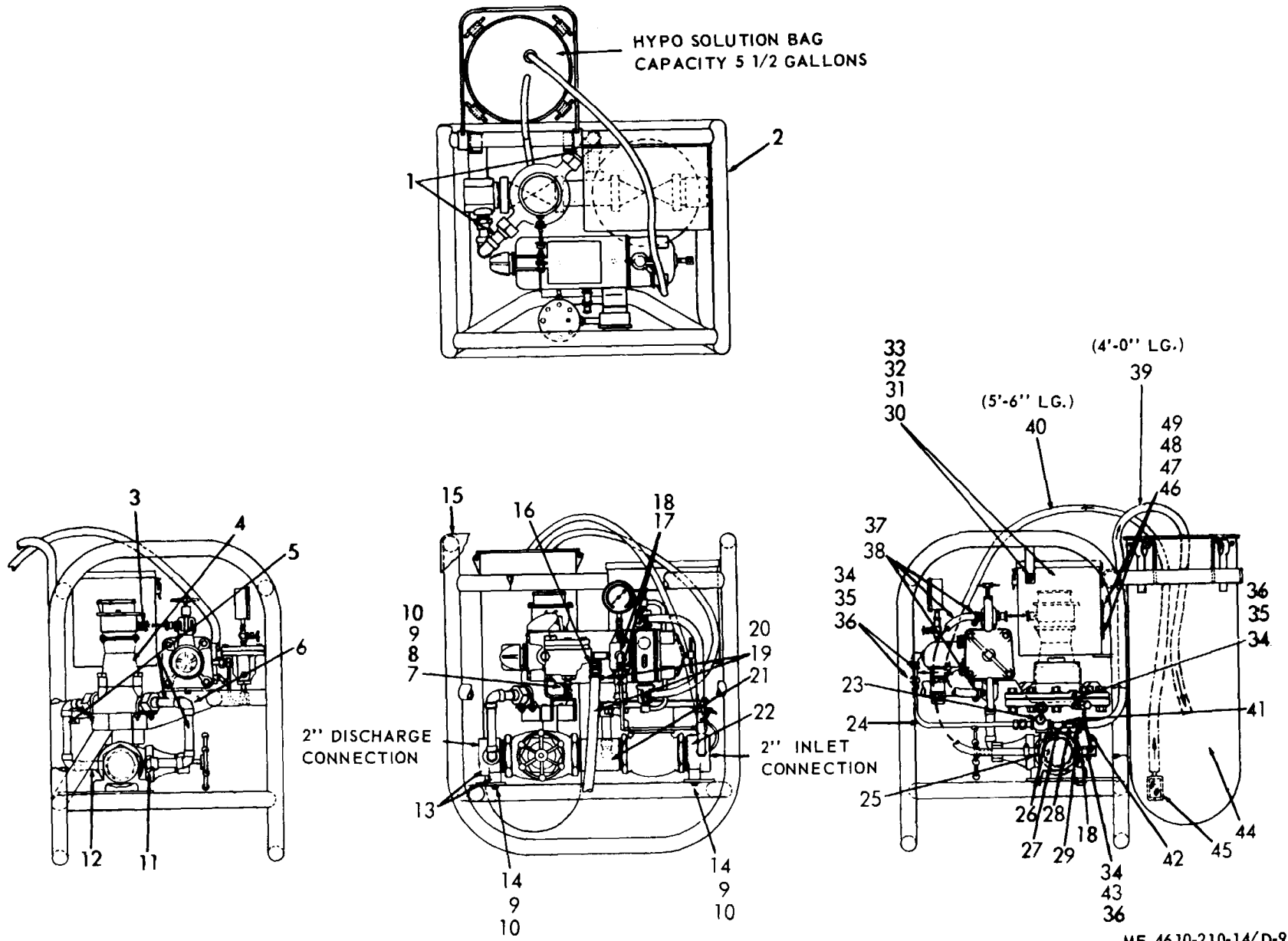

ME 4610-210-14/D-9

Figure D-9. Water Purification Unit

INDEX

	Paragraph	Page		Paragraph	Page
A					
Adjustment			Hypochlorinator assembly,		
Diaphragm, hypochlorinator	3-13	3-7	removal	3.12	3-5
Stroke control	2-8	2-5	Hypochhsrinator, disassembly	5.2	5-1
Administrative storage	1-3	1-1	I		
Assembly, hypochlorinator,			Identification	1-6	1-3
removal	3-12	3-5	Inspection	2-1	2-1
Assembly, register box, removal	3-11	3-4	Inspection of:		
B			Balancing water valve	3-17	3-11
Balancing water valve,			Block, poppet valves, and valve		
disassembly	5-4	5-5	seats	3.14	3-8
Balancing water valve, removal	5-4	5-5	Flow controller	3.17	3-11
Block, removal	3-14	3-8	Hypochlorinator assembly	3.12	3-5
Box, tool	3-7	3-3	Hypochlorinator diaphragm	3-13	3-7
C			Water meter assembly	3-10	3-3
Chart, treatment	2-10	2-7	Installation of separately packed		
Control, stroke	2-6	2-4	components	2.2	2-1
Controller, flow, disassembly	5-3	5-5	Installation or setting-up		
Controller, flow, removal	5-3	5-5	instructions	2-2	2-1
Controls and instruments	2-6	2-4	Instrument and controls	2-6	2-4
Cover	3-8	3-3	M		
D			Movement, dismantling for	2-3	2-4
Data, tabulated	1-6	1-3	Movement, reinstallation after	2-4	2-4
Description	1-5	1-1	O		
Destruction	1-4	1-1	Operation:		
Diaphragm, hypochlorinator,			In dusty or sandy areas	2-15	2-11
adjustment	3-13	3-7	In extreme cold	2-13	2-11
Diaphragm, hypochlorinator,			In salt water areas	2-14	2-11
removal	3-13	3-7	Of equipment	2-10	2-7
Difference in models	1-7	1-4	tinder unusual conditions	2-12	2-11
Direct and genral support repair			Under usual conditions	2-7	2-5
parts	4-2	4-1	With hard water	2-16	2-16
Dissassembly:			P		
Balancing water valve	5-4	5-5	Poppet valve removal	3-14	3-8
Flow controller	5-3	5-5	Preparation for starting	2-8	2-5
Hypochlorinator	5-2	5-1	Preparation of sterilizing		
Range adjustment valve	5-5	5-8	solution	2-11	2-8
Register box	3-11	3-4	Preventive maintenance checks		
Water meter	5-6	5-8	and services	3-4	3-1
Water pressure regulating			R		
valve	5-7	5-11	Range adjusting valve	2-6	2-4
E			Range adjusting valve,		
Equipment:			disassembly	5-5	5-8
Dismantling for movement	2-3	2-4	Range adjusting valve, removal	5-5	5-8
Installation	2-2	2-1	Register box, disassembly	3-11	3-4
Operation of	2-10	2-7	Register, water meter	2-6	2-4
Reinstallation after movement	2-4	2-4	Removal of:		
Starting	2-8	2-7	Balancing water valve	3-17	3-11
Stopping	2-9	2-4	Flow controller	3-17	3-11
F			Hypochlorinator assembly	3-12	3-5
Flow controller	2-6	1-1	Poppet valves	3-14	3-8
Flow rate	1-5	1-1	Range adjusting valve	3-16	3-9
Forms and records	1-2	2-4	Valve seats	3.14	3-8
G			Water pressure gage	3-9	3-3
Gage, water pressure	2-6		Water pressure regulating		
			valve	3-16	3-9
			Reporting of errors	1-2	1-1
			Reservoir, solution	3-15	3-9

INDEX - Continued

	Paragraph	Page		Paragraph	Page
S					
Scope	1-1	1-1			
Seat, valve, removal	3-14	3-8			
Servicing	2-1	2-1			
Shipping dimensions.	1-6	1-4			
Solution reservoir	3-15	3-8			
Solution, strength of	2-11	2-8			
Special tools and equipment	4-1	4-1			
Starting	2-8	2-5			
Sterilizing solution, preparation of	2-11	2-8			
Stopping	2-9	2-7			
Storage, administrative	1-3	1-1			
Stroke adjustment	2-8	2-5			
Stoke control	2-6	2-4			
T					
Tabulated data	1-6	1-3			
Toolbox	3-7	3-3			
Tools and equipment	3-1	3-1			
Treatment chart	2-10	2-7			
Troubleshooting.	3-6,4-4	3-3, 4-1			
			V		
			Valves:		
			Balancing water, disassembly	5-4	5-5
			Balancing water, removal	3-17	3-11
			Poppet, removal	3-14	3-8
			Range adjusting, disassembly	5-5	5-8
			Range adjusting, removal	5-5	5-8
			Water pressure regulating, disassembly	5-7	5-11
			Water pressure regulating, removal	3-16	3-9
			Water supply, hypochlorinator	2-6	2-4
			W		
			Water flow rate	1-5	1-1
			Water meter register	2-6	2-4
			Water meter, removal	3-10	3-3
			Water pressure gage	2-6	2-4
			Water pressure regulating valve	3-16	3-9
			Water supply valve	2-6	2-4

By Order of the Secretary of the Army:

W. C. WESTMORELAND,
General, United States Army,
Chief of Staff.

Official:

VERNE L. BOWERS,
Major General, United States Army,
The Adjutant General.

Distribution:

To be distributed in accordance with DA Form 12-25 (qty rqr Block No. 177),
Operator requirements for Equipment: Water Purification.

* U.S. GOVERNMENT PRINTING OFFICE: 1971—431-107/829

TM 5-4610-210-14 HYPOCHLORINATION UNIT, WATER PURIFICATION - 1971

027446